

ALESIS

DEQ830 (ME4)

Service Manual

P/N: 8-31-0117-A

ATTENTION!

THIS DOCUMENT CONTAINS SENSITIVE
PROPRIETARY INFORMATION. ALL
RECIPIENTS MUST HAVE A CURRENT NON-
DISCLOSURE AGREEMENT ON FILE WITH
ALESIS DISTRIBUTION, LLC.

**DO NOT DISTRIBUTE THIS DOCUMENT IN
ELECTRONIC FORM**

The information in this document contains privileged and confidential information. It is intended only for the use of those authorized by Alesis. If you are not the authorized, intended recipient, you are hereby notified that any review, dissemination, distribution or duplication of this document is strictly prohibited. If you are not authorized, please contact Alesis and destroy all copies of this document. You may contact Alesis at support@Alesis.com.

Copyright © 2002 Alesis Distribution, LLC

Preface

This document is intended to assist the service technician in the operation, maintenance and repair of the Alesis device. Together with the User Reference Manual, this document provides a complete description of the functionality and serviceability of the Device. Any comments or suggestions you may have pertaining to the document are welcome and encouraged.

READ THIS!

In addition to any purchase price that Alesis may charge as consideration for Alesis selling or otherwise transferring this service manual ("Manual") to you, if you are not a service and repair facility ("Service Center") authorized by Alesis in writing to be an authorized Service Center, Alesis sells or transfers the Manual to you on the following terms and conditions:

Only Service Centers authorized by Alesis in writing are authorized to perform service and repairs covered by an Alesis warranty (if any), and transfer of the Manual to you does not authorize you to be an authorized Service Center. **Therefore, if you perform, or if the Manual is used to perform, any service or repairs on any Alesis product or part thereof, any and all warranties of Alesis as to that product and any service contract with Alesis for that product shall be voided and shall no longer apply for such product, even if your services or repairs were done in accordance with the Manual.**

All service or repairs done by you or with reference to the Manual shall be solely your responsibility, and Alesis shall have no liability for any such repairs or service work. **All such service or repairs are performed at the sole risk of the person performing the service or repairs.** You agree that all such work will be performed in a competent, professional and safe manner at all times and to indemnify and fully hold Alesis and its successors and assigns harmless in the event of any failure to so perform.

Your purchase of the Manual shall be for your own ultimate use and shall not be for purposes of resale or other transfer.

As the owner of the copyright to the Manual, Alesis does not give you the right to copy the Manual, and you agree not to copy the Manual without the written authorization of Alesis. Alesis has no obligation to provide to you any correction of, or supplement to, the Manual, or any new or superseding version thereof.

Alesis shall have the right to refuse to sell or otherwise transfer repair parts or materials to you in its sole discretion. You shall not use, sell or otherwise transfer spare or replacement parts supplied by Alesis to you (i) to repair or be used in products manufactured for or by third parties or (ii) to any third parties for any purpose.

You shall not make any warranties or guarantees with respect to the products of Alesis or the use thereof on behalf of Alesis or in your own name.

The foregoing describes the entire understanding related to sale or transfer of the Manual to you, and no other terms shall apply unless in a writing signed by an authorized representative of Alesis.

All Trademarks are property of their respective companies.

Warnings

TO REDUCE THE RISK OF ELECTRIC SHOCK OR FIRE, DO NOT EXPOSE THIS PRODUCT TO WATER OR MOISTURE.



The arrowhead symbol on a lightning flash inside a triangle is intended to alert the user to the presence of un-insulated "dangerous voltage" within the enclosed product which may be of sufficient magnitude to constitute a risk of electric shock to persons.



The exclamation point inside a triangle is intended to alert the user to the presence of important operating, maintenance and servicing instructions in the literature which accompanies the product.

REPAIR BY ANY PERSON OR ENTITY OTHER THAN AN AUTHORIZED ALESIS SERVICE CENTER WILL VOID THE ALESIS WARRANTY.

PROVISION OF THIS MANUAL DOES NOT AUTHORIZE THE RECIPIENT TO COMPETE WITH ANY ALESIS DISTRIBUTOR OR AUTHORIZED REPAIR SERVICE CENTER IN THE PROVISION OF REPAIR SERVICES OR TO BE OR MAKE REPAIRS AS AN AUTHORIZED SERVICE CENTER.

ALL REPAIRS DONE BY ANY ENTITY OTHER THAN AN AUTHORIZED ALESIS SERVICE CENTER SHALL BE SOLELY THE RESPONSIBILITY OF THAT ENTITY, AND ALESIS SHALL HAVE NO LIABILITY TO THAT ENTITY OR TO ANY OTHER PARTY FOR ANY REPAIRS BY THAT ENTITY.

Safety Suggestions

Carefully read the applicable items of the operating instructions and these safety suggestions before using this product. Use extra care to follow the warnings written on the product itself and in the operating instructions. Keep the operating instructions and safety suggestions for reference in the future.

1. Power Source. The product should only be connected to a power supply which is described either in the operating instructions or in markings on the product.
2. Power Cord Protection. AC power supply cords should be placed such that no one is likely to step on the cords and such that nothing will be placed on or against them.
3. Periods of Non-use. If the product is not used for any significant period of time, the product's AC power supply cord should be unplugged from the AC outlet.
4. Foreign Objects and Liquids. Take care not to allow liquids to spill or objects to fall into any openings of the product.
5. Water or Moisture. The product should not be used near any water or in moisture.
6. Heat. Do not place the product near heat sources such as stoves, heat registers, radiators or other heat producing equipment.
7. Ventilation. When installing the product, make sure that the product has adequate ventilation. Improperly ventilating the product may cause overheating, which may damage the product.
8. Mounting. The product should only be used with a rack which the manufacturer recommends. The combination of the product and rack should be moved carefully. Quick movements, excessive force or uneven surfaces may overturn the combination which may damage the product and rack combination.
9. Cleaning. The product should only be cleaned as the manufacturer recommends.
10. Service. The user should only attempt the limited service or upkeep specifically described in the operating instructions for the user. For any other service required, the product should be taken to an authorized service center as described in the operating instructions.
11. Damage to the Product. Qualified service personnel should service the unit in certain situations including without limitation when:
 - a. Liquid has spilled or objects have fallen into the product,
 - b. The product is exposed to water or excessive moisture,
 - c. The AC power supply plug or cord is damaged,
 - d. The product shows an inappropriate change in performance or does not operate normally, or
 - e. The enclosure of the product has been damaged.

General Troubleshooting

While this manual assumes that the reader has a fundamental understanding of electronics and basic troubleshooting techniques, a review of some of techniques may help.

- **Visual Inspection** - A short visual inspection of the unit under test will often yield results without the need of complex signal analysis (burnt, or loose components are a dead giveaway).
- **Self Test** - Alesis products that utilize microprocessor control contain built in test software which exercises many of the units' primary circuit functions. Self test should always be done following any repair to ensure basic functionality.
- **Environmental Testing** - Applying heat and cold (heat gun/freeze spray) will often reveal thermally intermittent components (Clock crystals, I.C.s, and capacitors are particularly prone to this type of failure).
- **Burn in Testing** - Leaving a unit running overnight often reveals intermittent failures such as capacitors that begin to leak excess current after a significant amount of time.
- **Cable Checks** - Wiggling cables can reveal intermittent failures such as loose cables or poorly soldered headers. Remember to check power supply cables as well.
- **Flexing the PC Board** - Poor solder joints and broken traces can often be found by pressing the PC Board in various places.
- **Tapping Components** - Sometimes tapping on a component (particularly crystals) will cause it to fail.
- **Power Down/up** - Turning the unit off and back on rapidly several times may reveal odd reset and/or power supply failures.
- **Reset Threshold** - A Variac (variable transformer) can be used to check reset threshold levels. This can be particularly useful in helping customers with low line problems.
- **Compressors** - Using a compressor/limiter is often helpful when attempting to solve low level noise problems, as well as assisting with DAC adjustments.
- **Sweep Tests** - Sweep generators are very useful in checking the frequency response envelopes of anti-aliasing filters.
- **Piggybacking** - Piggybacking I.C.s is particularly useful when troubleshooting large sections of logic. This is especially true when working with older units.
- **Assembly/Disassembly Organization** - When removing assemblies, organize screws and clips with the assemblies that they were removed from. Organizer trays save a lot of time during re-assembly since similar screws and clips will not be mixed with each other.

SERVICE MANUAL

MODEL:DEQ-830

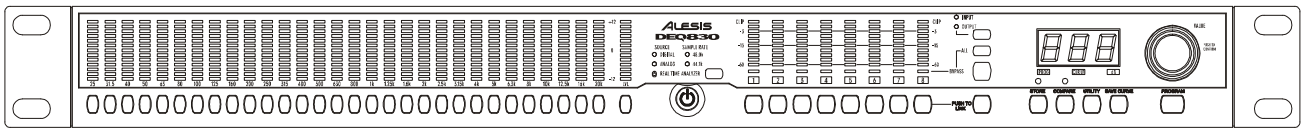

SPECIFICATION

Rear Panel I/O (switchable)

Analog:
Input Connectors: 8 balanced 1/4" TRS jacks
Output Connectors: 8 balanced 1/4" TRS jacks

Digital:
Input Connector: 1 ADAT Optical
Output Connector: 1 ADAT Optical

Switch set to +4:
Nominal input level: +4dBu (-15dBFS)
Maximum input level: +19dBu (6.9 Vrms)

Nominal Output Level: +4dBu (-15dBFS)
Maximum Output Level: +19dBu (6.9 Vrms)

Switch set to -10:
Nominal input level: -10dBV (-16dBFS)
Maximum input level: +6dBV (2.0 Vrms)

Nominal Output Level: -10dBV (-16dBFS)
Maximum Output Level: +6dBV (2.0 Vrms)

Input impedance: 10
Output Impedance: 22

MIDI:
MIDI Input: 1 5-pin female DIN
MIDI Output: 1 5-pin female DIN

Audio Performance

Signal To Noise Ratio: >100dB A-Weighted, Analog In to Analog Out
THD+N: <0.005%, Analog In to Analog Out
Frequency Response: 22-22kHz 0.50dB, Analog In

Power Consumption: to Analog Out
15 Watts Max (100-240 VAC / 50-60 Hz)

Mechanical

Size: 1.75" H x 19.0" W x 5" D
Rack Spaces: 1 Space
Weight: 3.0 lbs. (1.4 kg)

Description of the Front Panel

In this section we give you an overview of the front panel's features. Not all features are labeled, so you may want to reference the diagram of the DEQ830 on page 18 as you read this section.

Band Select

There are 31 buttons side-by-side on the left half of the DEQ830's front panel. The first 30 are the [BAND SELECT] buttons. Above each of the [BAND SELECT] buttons is a number like "25" or "8k." These stand for the audio frequencies, measured in Hertz (Hz), which are selected for editing by the [BAND SELECT] buttons below them. The 31 st button is the [CHANNEL LEVEL] button, which is explained in the next paragraph.

Channel Level

The [CHANNEL LEVEL] button is used to set the level of the currently selected channel or Link Group. This setting is post-EQ and pre-Master Level.

Real Time Analyzer (RTA)

This button will put the DEQ830 into Real Time Analyzer

mode, in which the unit serves as a visual aid for analyzing the audio signal. In this mode, the Band Gain LEDs "dance to the music," displaying the relative strengths of the various frequency ranges passing through the DEQ830.

Channel Select

To the right of the [POWER] button, you'll see the [CHANNEL SELECT] buttons. These eight buttons are used for selecting a channel for which the EQ settings will be displayed on the 30 Band Gain LEDs. The [CHANNEL SELECT] buttons are also used when you are creating Link Groups.

Monitor Select (INPUT/OUTPUT)

This button, located immediately above the [BYPASS] and [ALL] buttons, toggles between INPUT and OUTPUT to determine whether the Channel Meters are displaying the input or output levels. The green LEDs above this button indicate which monitoring method is currently selected.

Bypass

When you press this button, a red LED will light immediately above the currently selected channel. This means the DEQ830 is in Bypass mode for that channel. As long as this LED is lit, incoming audio will pass through that channel without being affected by its EQ settings. Also, if you're on a linked channel when you press the [BYPASS] button, all of the linked channels will bypass at the same time. Bypass mode is useful for comparing the "equalized" signal with the original signal so you can decide if you like the edit you made. Press the button again to get out of Bypass mode and hear the effect.

Bypass All (ALL)

This button is located just above the [BYPASS] button. It will toggle the Bypass status of all eight channels at once. The first press of the [ALL] button will cause any un-bypassed channels to enter Bypass mode, after which all eight channels will change their Bypass status together. When you press this button, the red LED below each channel meter will light. Press it again to return all eight channels to their effected state.

Link (PUSH TO LINK)

This button is used to link channels together so that their EQ settings are "mirrored." Any edits you make to a band on the original channel will also happen to that same band on all linked channels. This is useful for quickly setting up a program without having to make independent adjustments for each channel.

Store

Once you have made a program edit you would like to keep, press this button to enter Store mode. From there you can use the [VALUE] encoder to select one of the 100 memory locations to become the new home for the edited program.

Compare

This button will help you if you are editing a program and would like to hear how the program sounded before you edited it. Pressing this button will temporarily recall the original program, and pressing it a second time will restore the edited program. The green LED above this button lights to indicate that the Band Gain LEDs are now showing the EQ curve as it appeared before your edits.

Utility

If you press [UTILITY] while you are in Program mode, you will enter Utility mode, which lets you edit the Master Level, MIDI Settings, the internal clock rate and other global parameters. If you press this button at startup as the DEQ830's splash screen is displayed, you will enter Lock mode. This mode allows you to lock the front panel buttons.

Save Curve

Press [SAVE CURVE] to save a channel's EQ curve to the DEQ830's curve bank so that it can be retrieved at a later time. We've provided 100 locations (00-99) in which to save curves. Curves 00-49 contain factory presets, and curves 50-99 are blank. Any of the 100 curves may be modified and saved.

Program

If you want to cancel any action in progress and return to Program mode, just press the [PROGRAM] button.

Value Encoder (VALUE)

To the far right side, you'll see the [VALUE] encoder, which is used to edit the gain amount of the frequency you have selected with the [BAND SELECT] buttons. (It is also possible to select and edit several frequencies at once; more about this later.) The [VALUE] encoder is also used for all sorts of data entry, such as selecting programs and curves, changing global parameter values and so forth. Changes made with the [VALUE] encoder are reflected in the Numerical LED Display to the left of the knob.

Numerical LED Display

The three-digit LED display you see to the left of the [VALUE] encoder is always showing either a value or an abbreviated name. To help you know at a glance what sort of information the display is giving you, there are three green LEDs immediately below the Numerical LED Display:

- | | |
|--------------|--|
| PROG | If this LED is lit, this means the value in the display is a program number. You will see this when the unit is in Program mode or Store mode. |
| CURVE | When lit, this LED indicates that the number in the display is telling you which curve has been chosen. |
| dB | This LED tells you that the value in the display pertains to a gain change. |

The only time that none of these LEDs will be lit is when the DEQ830 is in Utility mode.

DISASSEMBLY PROCEDURES

1. REMOVAL OF TOP COVER / FRONT PANEL (Fig1)

- (A) TAKE OUT THE 3PC SCREWS FROM WHICH THE REAR PANEL.
- (B) TAKE OUT THE 3PC SCREWS FROM WHICH THE TOP PANEL.
- (C) TAKE OUT THE 3PC SCREWS FROM WHICH THE BOTTOM CHASSIS.

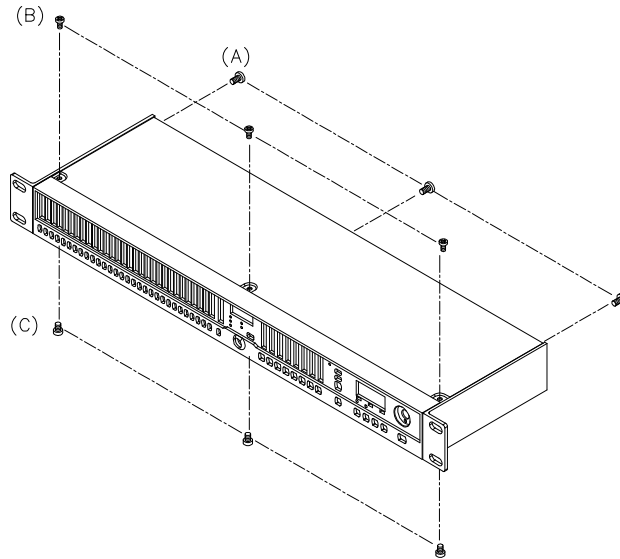

Fig.1

2. REMOVAL OF MAIN P.C.B (Fig2)

- (A) REMOVE THE 16 PCS NUT OF 1/4" CONNECTORS REAR PANEL.
- (B) REMOVE THE 4 PCS SCREW FROM WHICH MAIN P.C.B.
- (C) REMOVE THE 2 PCS SCREW FROM WHICH REAR PANEL.
- (D) REMOVE CABLE CONNECTOR FROM.
- (E) REMOVE THE SCREW FROM RCA SOCKET.

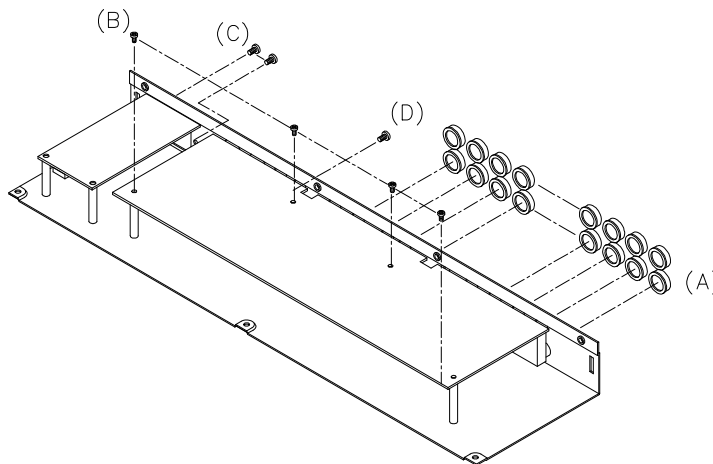

Fig.2

DISASSEMBLY PROCEDURES

3.REMOVAL OF FRONT PAREL P.C.B (Fig.3)

(A.) REMOVE THE 3PC OF SUB-PANEL.

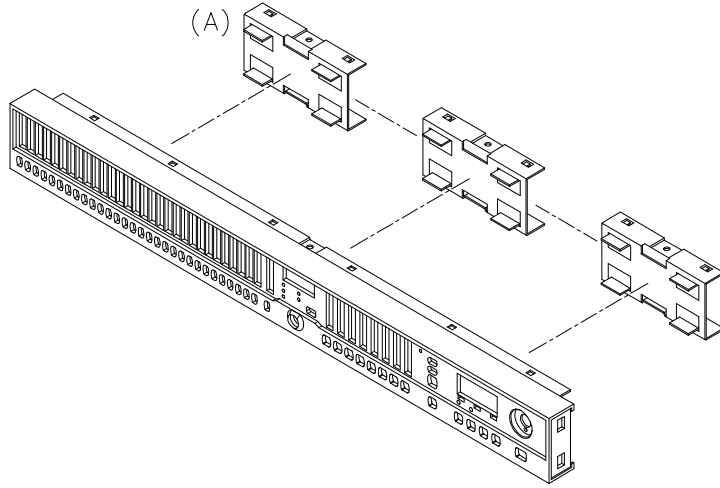
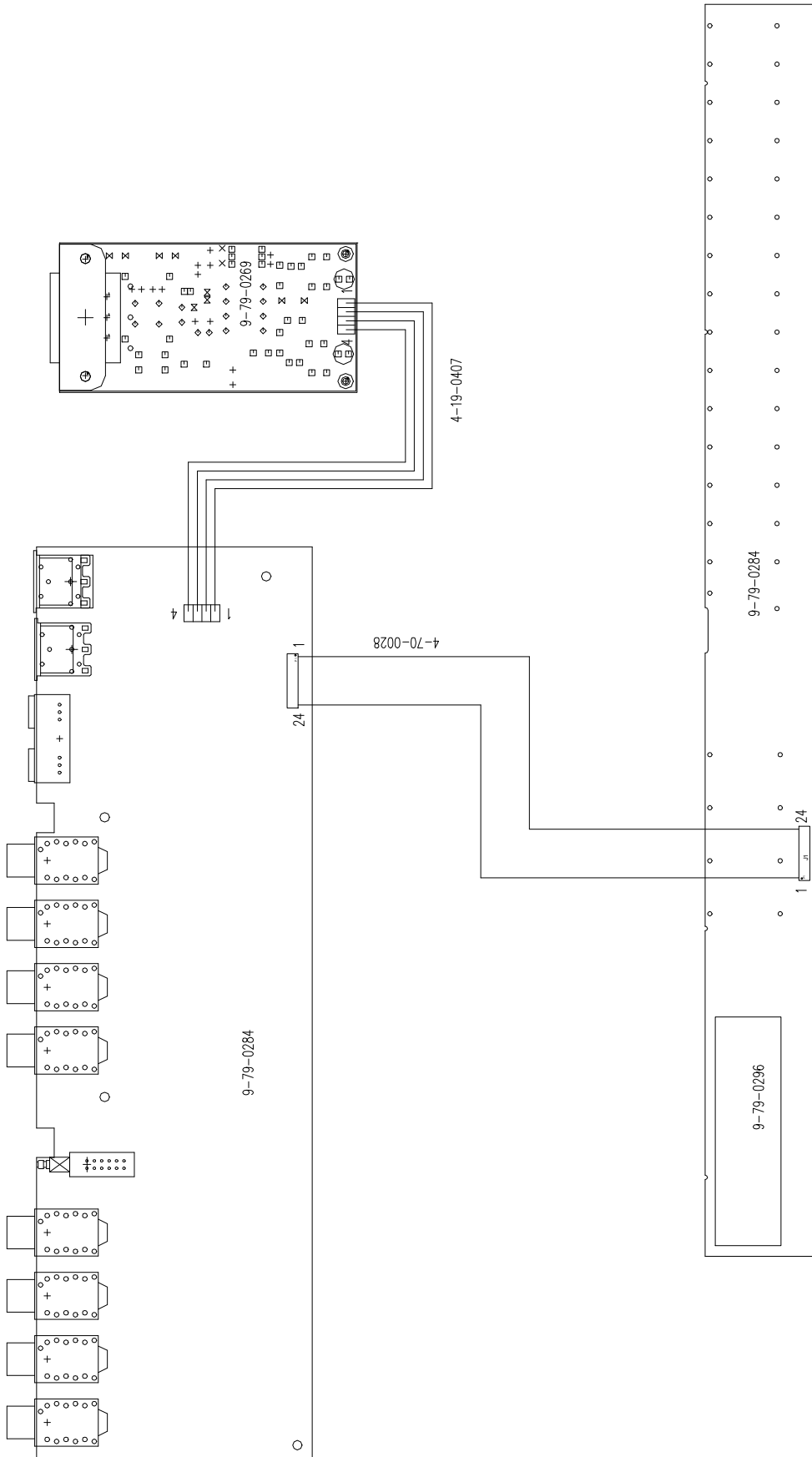

Fig.3

WIRING DIAGRAM

(US/EU/UK/AUS NZ)



PACKING DIAGRAM

(US/EU/UK/AUS NZ)

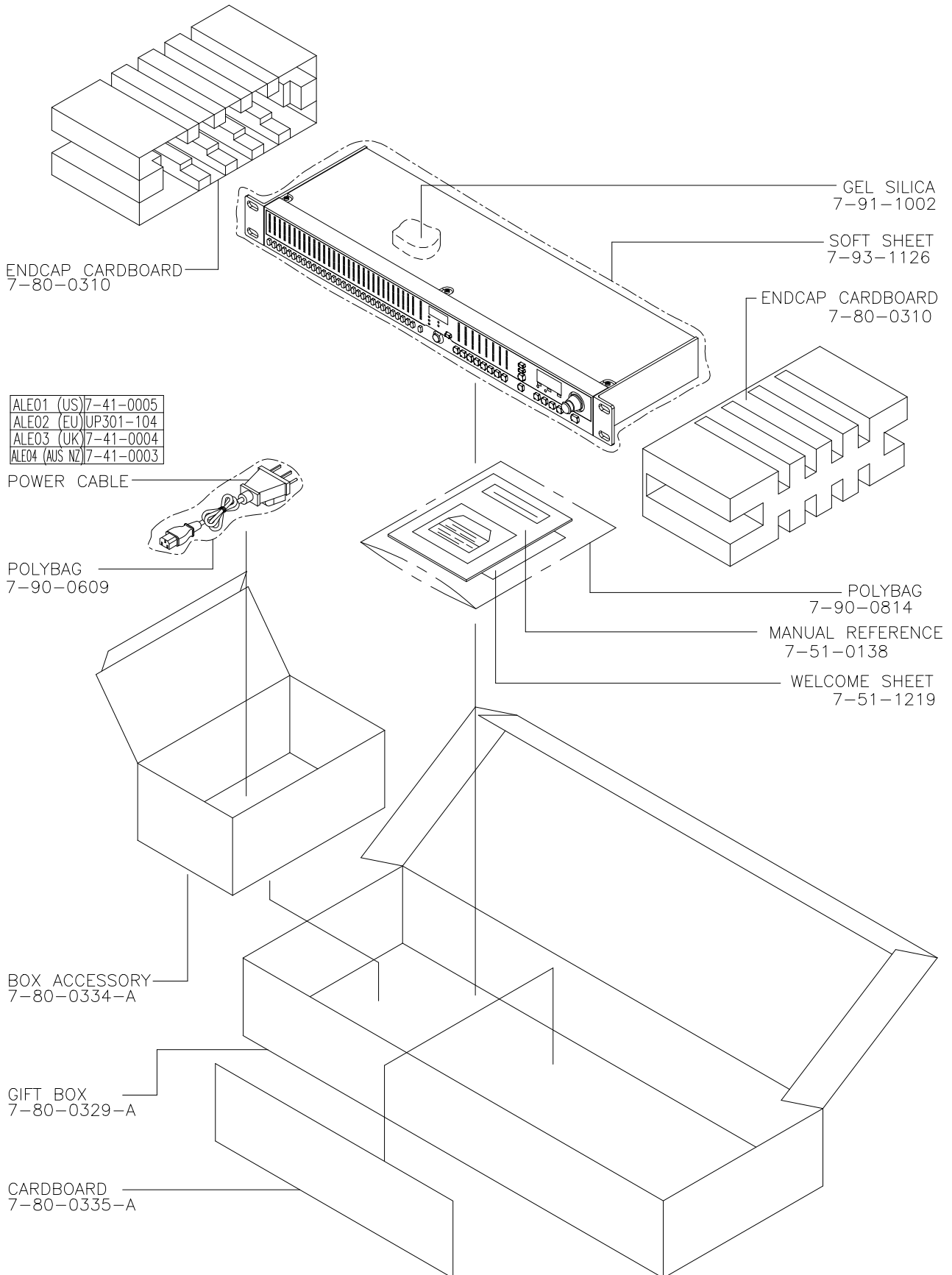

EXPLODE DIAGRAM (US/EU/UK/AUS NZ)

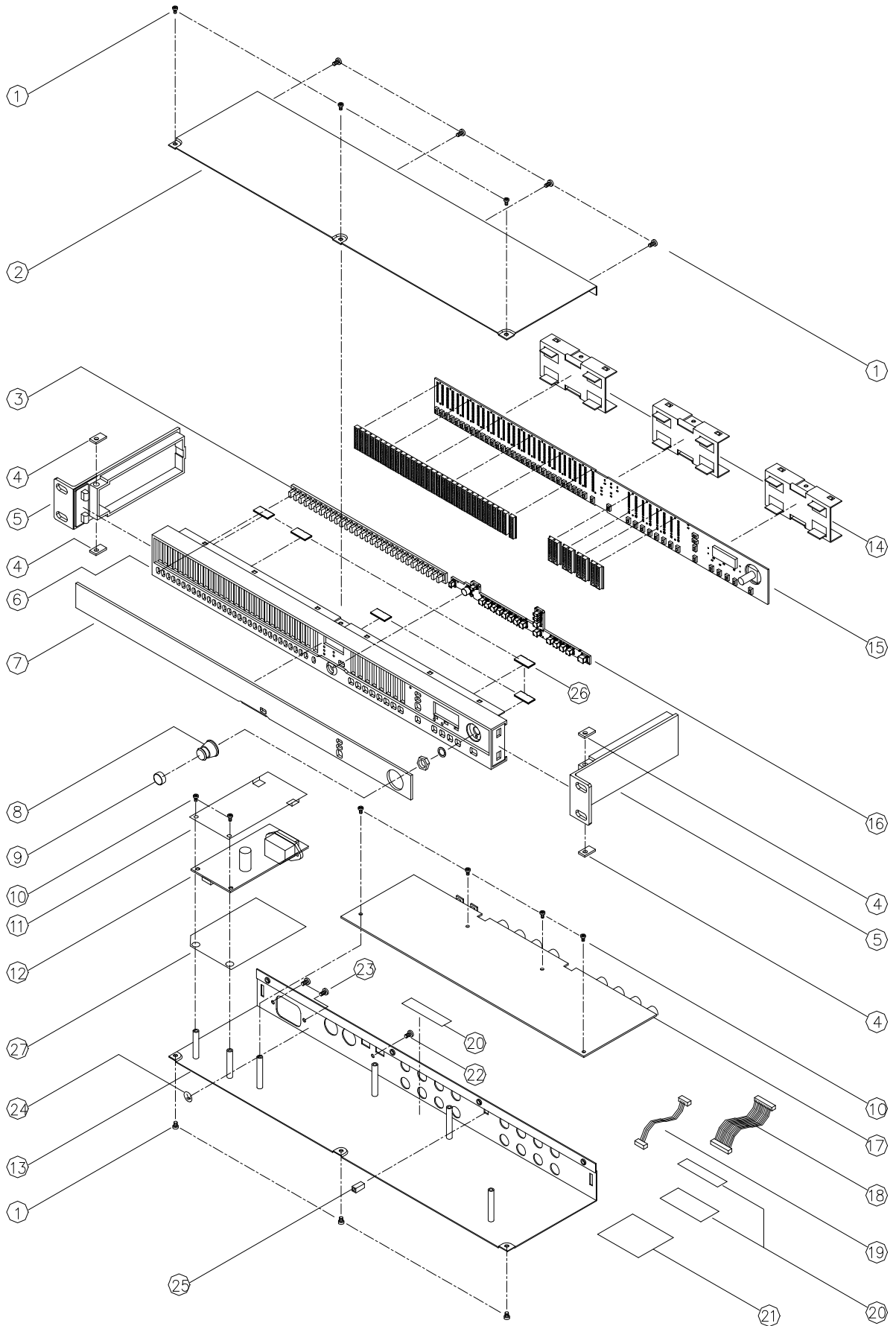

SEQUENTIAL NO OF EXPLODE DIAGRAM WILL BE MARKED ON REF. COLUMNM OF BOM LIST

DEQ830 BOM

LEVEL	P/N	DESCRIPTION	QTY	REF
1	7-50-0180	STICKER BARCODE S/N	1	20
1	LAP67YAH255	STICKER	1.4	
1	LA67YH104	STICKER	1	24
1	9-03-0061	CLIP EMC GND FRONT PANEL	6	26
1	9-02-0012	RACK EAR 1-U 128mm SILVER	2	5
1	9-03-0139	SUBPANEL	3	14
1	9-03-0147-A	CHASSIS TOP COVER	1	2
1	9-01-0059-A	CHASSIS	1	13
1	9-10-0060-A	BEZEL DISPLAY 2.5 THICK CLEAR	1	7
1	PDEQ830ALE01	PACKING ASSEMBLY	1	
2	7-80-0310	ENDCAP CARDBOARD/PRESSBOARD	2	
2	7-80-0335-A	CARDBOARD	1	
2	7-80-0334-A	ACCESSARY BOX	1	
2	7-80-0329-A	GIFT BOX	1	
2	7-80-0330-A	BOX SHIPPING FREIGHT (5 UNITS PER)	0.1	
2	7-51-0138-A	MANUAL REFERENCE	1	
2	7-90-0609	POLYBAG	0.14	
2	7-93-1126	BAG FOAM	1	
2	7-51-1219	SHEET "WELCOME TO ALESIS FAMILY" 5 x 8"	1	
2	7-91-1002	GEL SILICA 5G PACKET	1	
1	7-07-0056-A	INSULATOR SHEET	1	11
1	9-15-1099	CAP SWITCH 5 x 5mm	1	25
1	9-15-0323-A	KNOB VALUE	1	8
1	9-03-0148-A	PANEL FRONT	1	6
1	9-24-0002-A	GASKET	4	4
1	9-30-0023	KEYPAD RUBBER BAND-SELECT	1	3
1	9-30-0025-A	KEYPAD RUBBER CHAN SELECT	1	16
1	9-32-0021-A	KNOB SLEEVE RUBBER	1	9
1	SC0306RICI	SCREW M3x6mm	6	10
1	SC0308RBNI	SCREW M3X8mm PPB PHIL-SLOT	1	22
1	SC0410RACI	SCREW M4x10mm	2	23
1	SC3506AICI	SCREW M3.5X6mm	10	1
1	4-19-0407	CABLE 4-PIN	1	19
1	4-70-0028	CABLE 24-PIN	1	18
1	7-41-0005	POWER UL/CSA(SJT)	1	
1	7-52-0040	STICKER ETL/FCC/CE/C-TICK & CAUTION	1	21
1	7-07-0061-A	INSULATOR POWER SUPPLY FORMEX	1	27
1	9-79-0283	ASSY FRONT PANEL ME4		15
2	0-15-0101	RES 100OHM 1/10W 5% 0805	1	R36
2	0-15-0102	RES 1K OHM 1/10W 5% 0805	1	R37
2	0-15-0820	RES 82 OHM 1/10W 5% 0805	6	R38-43
2	0-17-0101	RES CHIP ARRAY 4 X 100 OHM 1/16W 5%	4	R1,2,19,22
2	0-17-0102	RES CHIP ARRAY 4 X 1K OHM 1/16W 5%	18	R3-6,11,14-18,20,21,27-29,32,34,35
2	0-17-0560	RES CHIP ARRAY 4 X 56 OHM 1/16W 5%	12	R7-10,12,13,23-26,30,31
2	1-56-0103	CAP 0.01UF	10	C1-8,10,13
2	1-56-0104	CAP 0.1UF	1	C18
2	1-56-0474	CAP 0.47UF	5	C11,12,14-16
2	1-60-3222	CAP 22UF ELEC 16V	1	C17
2	2-51-4401	TRANS NPN 2N4401	43	Q17-59
2	2-54-0064	TRANS PNP 2N4403	16	Q1-16
2	2-62-0595	IC 74HC595	8	U2-6,8,9,11
2	2-69-2456	IC EEPROM SERAIL 256K-BIT	1	U10
2	3-02-0048	LED BLUE	6	D512-517
2	3-20-0009	LED GREEN	99	D7,20,33,46,59,72,85,98,111,124,137,150,163,176,189,202,215,228,241,254,267,280,293,306,319,332,345,358,371,384,397,404-407,412-417,420,425-430,433,438-443,446,451-456,459,464-469,472,477-482,485,490-495,498,503-508,511,520-526,528

2	3-20-0010	LED YELLOW	404	D1~6,8~19,21~32,34~45,47~58,60~71,73~84,86~97,99~110,112~123,125~136,138~149,151~162,164~175,177~188,190~201,203~214,216~227,229~240,242~253,255~266,268~279,281~292,294~305,307~318,320~331,333~344,346~357,359~370,372~383,385~396,398~403,409~411,419,422~424,432,435~437,445,448~450,458,461~463,471,474~476,484,487~489,497,500~502,510
2	3-20-0011	LED RED	16	D408,418,421,431,434,444,447,457,460,470,473,483,486,496,499,509
2	4-20-1002	10PIN CONNECTOR	2	CN1,CN2
2	4-20-0242	HEADER DIL 24-PIN	1	J1
2	6-02-0055	SWITCH TACT	50	S1~17,26~49,SS17~25
2	7-01-0040	RESONATOR 18MHz	1	M1
2	9-40-0283	FUNCTION PCB	1	
2	9-15-0295	FRAME LED 6-COLUMNS x 13 LEDS	5	
2	9-15-0373-A	FRAME LED 2 COLUMN CHANNEL METER	4	
2	9-15-0372-A	FRAME LED 1- COLUMN x 13 LEDS	1	
2	9-61-0090	IC89C51rd+iB	1	U1
1	9-79-0284	ASSY REAR PANEL ME4		17
2	0-15-0101	RES 100 OHM 1/10W 5%	1	R224
2	0-15-0103	RES 10K OHM 1/10W 5%	7	R41,59,263~266,268
2	0-15-0113	RES 11K OHM 1/10W 5%	16	R3,4,43,44,76,77,84,85,98,99,106,107,124,125,132,133
2	0-15-0133	RES 13K OHM 1/10W 5%	16	R15,16,26,27,144,145,166~169,190,191,200,201,222,223
2	0-15-0163	RES 16K OHM 1/10W 5%	16	R1,2,45,46,74,75,86,87,96,97,108,109,122,123,134,135
2	0-15-0182	RES 1.8K OHM 1/10W 5%	16	R5,10,39,40,80,81,88,89,94,95,102,103,128,129,136,137
2	0-15-0221	RES 220 OHM 1/10W 5%	3	R34,37,38
2	0-15-0331	RES 330 OHM 1/10W 5%	65	R28~33,35,47~52,60,61,63,66,67,90~93,138~143,159,160,175,176,192~199,215,216,225~228,245~262,267
2	0-15-0392	RES 3.9K OHM 1/10W 5%	32	R20,56,58,64,68,73,110,115,116,121,151,156,179,184,207,212,229~244
2	0-15-0512	RES 5.1K OHM 1/10W 5%	16	R11,12,24,25,146,147,164,165,170,171,188,189,202,203,220,221
2	0-15-0622	RES 6.2K OHM 1/10W 5%	16	R13,14,17,23,148,161~163,172~174,187,204,217~219
2	0-15-0912	RES 9.1K OHM 1/10W 5%	64	R6~9,18,19,21,22,36,42,53~55,57,62,65,69~72,78,79,82,83,100,101,104,105,111~114,117~120,126,127,130,131,149,150,152~155,157,158,177,178,180~183,185,186,205,206,208~211,213,214
2	1-08-0222	CAP 22UF ELEC 16V	37	C3,8,32,33,35,40,47,49,50,52~57,61,62,68,69,82,83,89,90,97,98,104,105,152,154~161,165
2	1-08-0228	CAP 2200UF ELEC 16V	1	C41
2	1-55-0561	CAP 560PF NPO	48	C1,2,4~7,10,20,23~26,58,59,64,65,70,71,76,77,86,87,92~95,100,101,106,107,115~117,119~121,124~126,128~130,143,144,145,147~149
2	1-56-0103	CAP 0.01UF	63	C11~13,15~19,27~31,34,36~39,42~46,48,51,60,63,66,67,72~75,80,81,84,85,88,91,96,99,102,103,108~112,118,127,133~140,146,162,163,166,167
2	1-56-0151	CAP 150PF	16	C3,14,21,22,70,73,113,114,122,123,131,132,141,142,150,154
2	2-11-2940	REG VOLTAGE LM2940C	3	U7,9,42
2	2-11-7905	REG VOLTAGE LM7905	1	U5
2	2-24-0138	IC 6N138	1	U12
2	2-27-0051	ASIC OPTO-REC AL1402	1	U39
2	2-27-0056	ASIC OPTOGEN AL1401A	1	U8
2	2-51-4401	TRANS NPN 2N4401	1	Q1
2	2-62-0000	IC 74HC00	2	U10,40
2	2-71-0084	IC TL084	12	U1~3,6,13,18,20,28,31~33,37
2	2-73-4053	IC CD4053	8	U14,15,21,24,27,29,34,35
2	2-75-1101	IC AL1101	4	U16,19,23,25
2	2-75-1201	IC AL1201	4	U4,30,36,38
2	2-77-0095	IC DSP 1KS/AL3102	5	U11,17,22,26,41
2	4-00-0002	JACK DIN 5-PIN MIDI PCB MOUNT	2	J10,11
2	4-02-0902	JACK 1/4" STEREO DUAL STACKED	8	J1~8
2	4-11-0001	CON FIBER-OPTIC	1	J9
2	4-14-0242	HEADER DIL 24-PIN	1	J12
2	4-15-0204	HEADERSIL 4-PIN	1	J13

2	5-02-0009	HEATSTNK	2	(U5,7)
2	6-02-0014	SWITCH	1	S1
2	9-40-0284	I/O PCB	1	
2	7-13-0036-A	HEATSINK ALUM 23.5mm x 16mm	1	
2	5-04-0061-A	INSULATOR 4.1mm x 18mm PLASTIC	1	
2	SC0308RBZI	SCREW	2	
2	SC0308RIZI	SCREW	2	
2	5-01-0029	WASHER	2	
1	9-79-0296	SENSOR PCB ASSY ME4		
2	3-04-0014	LED DISP 7-SEG	1	D527
2	6-00-0009	ENCODER 15-DETENT	1	S50
2	5-04-0063-A	LCD FRAME	1	
1	9-79-BB01	ASSY BB01 POWER SUPPLY		12
2	JW5206T	JUMP WIRE	1	J3
2	NUT0130IZI	NUT	1	(Q2)
2	SC0308RIZI	SCREW	1	(Q2)
2	5-04-0007	WASHER	1	(Q2)
2	0-00-0221	RES 220 OHM 1/8W 5%	1	R1
2	0-00-0689	RES 6.8 OHM 1/8W 5%	1	R2
2	0-01-2213	RES 221K OHM 1/8W 5%	2	R3,4
2	0-05-1104	RES 100K OHM 1W 5%	1	R5
2	1-02-0104	CAP 0.1UF	1	C1
2	1-02-5103	CAP 0.01UF	1	C6
2	1-08-0474	CAP 47UF ELEC 16V	1	C5
2	1-08-1000	CAP 1000UF ELEC 16V	2	C7,9
2	1-09-0221	CAP 220UF ELEC 25V	4	C2,4,10,12
2	1-13-4472	CAP 47UF ELEC400V	1	C11
2	1-14-0104	CAP 0.1UF X2-CAP +/-20% 250VAC	2	C3,8
2	1-15-0103	ELECT 0.01UF/250VAC	2	C14,15
2	1-15-2102	CAP 1000PF Y-CAP 250VAC	1	C13
2	2-01-0120	DIODE MUR120	2	D2,6
2	2-01-5822	DIODE 1N5822	1	D3
2	2-02-0600	DIODE MUR160	1	D4
2	2-02-4751	DIODE 1N4751	1	D5
2	2-03-0105	RECTIFIER BRIDGE DB 105 600V 1A	1	D7
2	2-05-0223	TRANS OFF-LINE PWM SWITCH	1	Q2
2	2-24-8104	IC OPTO-ISOLATOR TCDT1124	1	Q1
2	2-99-0021	DIODE BAV21	1	D1
2	4-09-0010	CON PWR IEC 10A 250V	1	J2
2	4-15-0204	HEADER SIL 4-PIN	1	J1
2	5-05-1001	CLIP FUSE HOLDER 5 X 12mm	1	F1
2	7-04-0012	FUSE 2A 250V 5X20mm F UL-LISTED	1	Install with F1
2	7-13-0035	HEATSINK	1	(Q2)
2	7-20-0064	INDUCTOR 100uH	2	L1,4
2	7-20-0065	INDUCTOR 22uH	1	L2
2	7-30-0025	CHOKE COMMON MODE 10mH	1	L3
2	7-40-0038	TRANSFORMER HI-FREQ SWITCHING FLYBACK	1	T1
2	9-07-0031	SHIELD EMI/IEC BB	1	
2	9-40-BB01	PCB POWER SUPPLY 10W - REV B	1	
2	7-53-0231-A	STICKER FUSE RATING T1AL 250V	1	
2	5-04-0062-A	INSULATOR 19mm x 20mm PLASTIC	1	
2	5-01-0029	WASHER	1	
2	5-01-0035	WASHER	1	
2	7-07-0023	INSULATOR PPLY PAD	1	

ME4 QC Test Procedures

Purpose: Explains test procedures for ME4 (DEQ-230D) for quality assurance of sub-assembly electronic functionality and audio fidelity, and final assembly functionality.

NOTE! These procedures DO NOT contain tests for safety/EMC compliance, or structural, assembly, or packaging quality.

Original Document Type: Word 2000

Current Revision: 1.00 **FINAL APPROVED FOR MASS PRODUCTION.**

Revision History:

10/25/2002	0.01	Initial Revision. Copied from ME3 Final QC. Updated for ME4. Peter Maresh
02/24/2003	0.02	Completed Revision Peter Maresh
03/31/2003	1.00	Changed analog tests to work at -10dBV nom. Changed analog test label in diagnostics menu. Moved to version 1.00 Peter Maresh

Questions or Comments Contact

Peter Maresh

Design Engineer, Alesis Studio Electronics, Los Angeles

pmaresh@alesis.com

Taiho Yamada

ME4 Project Manager, Alesis Studio Electronics, Los Angeles

tyamada@alesis.com

Contents

1) QC Test Overview.....	3
1a) Diagnostic Menus.....	4
DIAG.....	4
EEPROM.....	4
COL.....	4
ROW.....	4
ALL.....	4
MIDI.....	4
A.....	4
DIG A.....	4
RESET.....	4
DONE.....	4
2) Rear Panel Sub Assembly Test - Digital.....	5
Items Required.....	5
Assembly.....	5
Power Test.....	6
Digital and MIDI Test.....	7
3) Rear Panel Sub Assembly Test - Analog.....	10
Items Required.....	10
Assembly.....	10
Power Test.....	11
Audio Fidelity Test.....	12
4) Front Panel Sub Assembly Test.....	14
Items Required.....	14
Assembly.....	14
Power Test.....	14
Front Panel Test.....	15
5) Assembly QC.....	27
Before the cover is screwed on.....	27
After the cover has been screwed on.....	27
6) Final Assembly QC.....	28
Items Required.....	28
Assembly.....	28
Power Test.....	28
System Test.....	28
7) Reset.....	41
Items Required.....	41
Reset.....	41

1) QC Test Overview

QC tests are performed at two primary stages, sub-assembly level, and final assembly level. Although several of the procedures are repeated during both stages, the sub-assembly level tests are designed to test all functionality of the electronic sub-assemblies, while the final assembly tests are designed to catch assembly errors. Between the sub-assembly and final assembly tests, the unit should be inspected for mechanical assembly quality. After the tests, the unit is Reset before being packaged.

Note that these tests are for the unit assembly. These tests do not include packaging and shipping QC.

The structure of the tests are as follows:

Electronic Sub-Assemblies QC

Rear Panel - Digital

- Test Power for operation
- Test MIDI for electrical operation
- Test Digital Input for electrical operation
- Test Digital Output for electrical operation

Rear Panel - Analog

- Test Audio Fidelity for electrical operation

Front Panel

- Test Buttons for electrical operation
- Test LED display for electrical operation
- Test EEPROM for electrical operation

Assembly QC

Specifics of this QC are to be supplied by manufacturer.

The unit should be inspected before the top panel is closed for correct assembly. All screws, sub-panel assembly, cabling should be inspected for completion and correctness.

Inspection for appearance and mechanical completion after the top panel is closed for correct final assembly. All external screws, nuts, washers, plastic finish, metal finish, and silkscreen should be inspected for completion, quality and correctness. There should be no scratches and the colors and text should be verified against the **latest** design for both the front and back of the unit.

Final Assembly QC

- Test LED display for appearance
- Test Switches for mechanical connectivity
- Test Audio for Sub-Assembly connectivity
 - Test Digital In to Analog Out
- Test Power for Sub-Assembly connectivity

Reset System

System is Reset for final packaging.

1a) Diagnostic Menus

When entering diagnostic mode, pressing PROGRAM will advance to the next test. The test order is as follows:

```
DIAG -> EEPROM -> COL -> ROW -> ALL -> MIDI -> A. ->  
DIG A. ->RESET -> DONE
```

DIAG

Message

Informs user "Prepare for tests."

EEPROM

Eeprom Test

When entering EEPROM test, EEPROM test is run automatically. Unit displays EEPROM FAIL or EEPROM PASS.

COL

LED Test

Turning the VALUE encoder clockwise rotates through LED columns.

ROW

LED Test

Turning the VALUE encoder clockwise rotates through LED rows.

ALL

LED Test

When entering ALL test, unit turns all LEDs on.

MIDI

MIDI Test

When entering MIDI test, MIDI test is run automatically. Unit displays MIDI FAIL or MIDI PASS. Requires MIDI loopback cable to PASS.

A.

Audio Fidelity Test

When entering AUDIO test, unit configures dsp for bypass to run audio tests. This uses an abbreviated title, "A," to reduce noise caused by the led matrix scanning.

DIG A.

Digital Audio Test

When entering DIG AUDIO test, digital audio test is run automatically. Unit displays DIG PASS or DIG FAIL. Requires ADAT Optical loopback cable to PASS.

RESET

EEPROM Reset

Allows user to reset EEPROM. Push encoder to RESET eeprom. Unit displays 0 to 99 in the 7 segment display, and is finished when the display reaches "99".

DONE

Message

Informs user "Done with tests."

2) Rear Panel Sub Assembly Test - Digital

Items Required

- 1 ME4 Rear Panel (DUT)
- 1 Known Good ME4 Front Panel Sub-Assembly (Front Panel)
This front panel should have been reset as described in Section 7 "RESET."
- 1 Known Good BB01 Power Supply with internal 4-pin power cable
- 1 IEC power cable
- 1 ADAT Optical cable
- 1 24 pin DIL cable for Rear Panel to Front Panel connection.
- 1 5-pin DIN Male to Male standard MIDI cable

Assembly

- 1) Connect **24 pin DIL cable** from the **Front Panel J6** to the **DUT J12**. Be sure that the Pin 1 stripe on the cable is oriented correctly on both sub-assemblies.
- 2) Connect the 4 pin clip-lock power cable from the **BB01 Power Supply** to the **DUT J13**.
- 3) Connect the **5-pin DIN Male to Male MIDI Cable** from the **MIDI IN jack** to the **MIDI OUT jack**.
- 4) Sub Assembly is ready for testing. Continue with Power Test.

Rear Panel Sub Assembly Test - DIGITAL CON'T

Power Test

- 1) Before applying power, visually inspect the DUT for major assembly problems.

Verify that U9 has a metal heat-sink that has been properly screwed tightly to the metal tab with heat conducting gel.

Verify that U7, U5 has been installed correctly and that the metal tab has been screwed to the HEAT SINK plane and is making a good connection to the plane.

Verify all Electrolytic capacitors for correct orientation.
C35, C55, C56, C40, C41, C165

C5, C13, C10, C65, C66, C64, C101, C102, C100, C86, C85, C87

C52, C50, C47, C49, C54, C53, C57, C152, C157, C156, C154, C155, C159, C160, C161

Problems with this inspection indicate that the DUT has FAILED.

Failure of this inspection indicate that the DUT cannot continue further testing.

- 2) Plug the **IEC Power Cable** into a power source and BB01.

Verify that the front panel LEDs show normal power up message, "DEQ830" on the left side.

Verify that the LEDs do not flicker and are of a consistent brightness.

Problems with this inspection indicates that the rear panel is not supplying the correct voltage to the Front Panel. Double check that the 24 pin DIL cable has been installed correctly. If this is not the problem, then the DUT has FAILED.

Failure of this test indicates that this sub-assembly cannot continue further testing. Quickly check the ICs on the Front Panel. If any are hot, or if there is any other indication that the Front Panel may have been damaged (burning smell, etc.), follow QC procedures to check the Front Panel, because the faulty DUT power supply may have damaged the Known Good Front Panel.

- 3) Unplug the **IEC Power Cable** to the **BB01 Power Supply**. Continue with Audio Fidelity Test if **DUT** has not failed.

Rear Panel Sub Assembly Test - DIGITAL CON'T

Digital and MIDI Test

1) Press the UTILITY and CHANNEL 7 buttons on the **Known Good ME4 Front Panel Sub-Assembly** and hold these buttons during Step 2. When started in this manner, the unit will enter Factory Test Mode. Please Note Section 1b on the Diagnostic Mode.

2) Plug the **IEC Power Cable** into a power source and BB01.

Verify that the front panel LEDs show normal power up message, "DEQ830" on the left side..
After this message "DIAG: <version>" should display on the left side. Verify that the version is the correct, shipping version number for the ME4.

Problems with this inspection indicates that the unit has not entered Factory Test Mode. Unplug the unit and repeat steps 1 and 2.

Problems with the correct version number indicate that the **Known Good ME4 Front Panel** has the incorrect software in it, and that it should be updated to the most recent software.

Failure of this test indicates that this sub-assembly cannot continue further testing.

3) When in Factory Test Mode, pressing PROGRAM will go to next test. Press PROGRAM.

Verify that the front panel LEDs shows first test message "EEPROM" for 1 second.

Verify that the front panel LEDs shows first test message "EEPROM PASS".

Problems with this inspection indicates that the unit is having trouble recognizing the PROGRAM button, or that the EEPROM has failed.

Failure of this test indicates that there is something wrong with the ME4 Known Good Front Panel.

4) Press PROGRAM until unit displays "MIDI."

Verify that the front panel LEDs shows test messages:

EEPROM -> COL -> ROW -> ALL -> SWITCH

STOP here.

Rear Panel Sub Assembly Test - DIGITAL CON'T

- 5) Press PROGRAM. This runs the MIDI test.

Verify that the front panel LEDs shows test "MIDI" for 1 second.

Verify that display shows "MIDI PASS".

Problems with this inspection indicate that there is a MIDI electrical or cabling problem. Try adjusting or replacing the MIDI Cable, unplug the IEC Cable and repeat steps 1 through 5. If the error message still shows after adjusting the cable, then the DUT has FAILED.

Failure of this test indicates that this sub-assembly cannot continue further testing.

- 6) Press PROGRAM once to advance to the audio ("A.") test.

- 7) Connect one end of the **ADAT Optical** cable from **DUT Optical OUT** to **DUT Optical IN**.

Verify that the source indicator in the middle of the front panel shows the audio switching from "ANALOG" to "DIGITAL", and that the "DIGITAL" indicator stays lit solid.

Problems with this inspection indicate that there is a optical audio problem. Try adjusting or replacing the ADAT Optical Cable, unplug the IEC Cable and repeat steps 1 through 6. Also, verify that the Known Good Front Panel has been properly RESET as described in Section 7 "RESET". If after resetting the Front Panel and adjusting the loopback cable, the unit does not switch to "DIGITAL" then there is a problem with ADAT Optical and the DUT has FAILED.

Failure of this test indicates that this sub-assembly cannot continue further testing.

- 8) Press PROGRAM once to continue to the DIG AUDIO test. The analog audio test will be performed later.

Verify that the front panel LEDs shows test messages:

MIDI -> A. -> DIG A.

Stop here.

Verify that the front panel LEDs shows test "DIG A." for 1 second.

Verify that display shows "DIG PASS".

Problems with this inspection indicate that there is a ADAT Optical electrical or cabling problem. Try adjusting or replacing the ADAT Optical Cable, unplug the IEC Cable and repeat steps 1 through 6. If the error message still shows after adjusting the cable, then the DUT has FAILED.

Failure of this test indicates that this sub-assembly cannot continue further testing.

- 9) Unplug the **IEC Power Cable** to the **BB01 Power Supply**. Then unplug all other cabling to the **DUT**. This is the end of the Rear Panel Sub-Assembly Analog test. Proceed to the Rear Panel Sub-Assembly Digital test.

3) Rear Panel Sub Assembly Test - Analog

Items Required

- 1 ME4 Rear Panel (DUT)
- 1 Known Good ME4 Front Panel Sub-Assembly (Front Panel)
This front panel should have been reset as described in Section 6 "RESET."
- 1 Known Good BB01 Power Supply with internal 4-pin power cable
- 1 IEC power cable
- 1 Computer with AP test equipment, s1_210k software, and ME4 test procedure installed in directory "C:\ME4\".
- 8 Female XLR to ¼" TRS audio cable
- 8 Male XLR to ¼" TRS audio cable
- 1 24 pin DIL cable for Rear Panel to Front Panel connection.

Assembly

- 1) Connect one **Female XLR to ¼" TRS audio cable** from **AP unit channel 1 OUT** to **DUT channel 1 IN**.

Repeat for **channel 2** through **channel 8**.
- 2) Connect one **Male XLR to ¼" TRS audio cable** from **AP unit channel 1 IN** to **DUT channel 1 OUT**.

Repeat for **channel 2** through **channel 8**.
- 3) Connect **24 pin DIL cable** from the **Front Panel J6** to the **DUT J12**. Be sure that the Pin 1 stripe on the cable is oriented correctly on both sub-assemblies.
- 4) Connect the 4 pin clip-lock power cable from the **BB01 Power Supply** to the **DUT J13**.
- 5) Boot the computer into DOS mode and go into directory "C:\ME4." For details on how to configure the test files, see "C:\ME4\README.TXT". Type "startup" to start the test program.
- 6) Select "-10dBV" on the **DUT** switch, near the ¼" jacks. The correct position is for the switch to be OUT.
- 7) Sub Assembly is ready for testing. Continue with Power Test.

Rear Panel Sub Assembly Test - ANALOG CON'T

Power Test

- 1) Plug the **IEC Power Cable** into a power source and BB01.

Verify that the front panel LEDs show normal power up message, "DEQ830" on the left side.

Verify that the LEDs do not flicker and are of a consistent brightness.

Problems with this inspection indicates that the rear panel is not supplying the correct voltage to the Front Panel. Double check that the 24 pin DIL cable has been installed correctly. If this is not the problem, then the DUT has FAILED.

Failure of this test indicates that this sub-assembly cannot continue further testing. Quickly check the ICs on the Front Panel. If any are hot, or if there is any other indication that the Front Panel may have been damaged (burning smell, etc.), follow QC procedures to check the Front Panel, because the faulty DUT power supply may have damaged the Known Good Front Panel.

- 2) Unplug the **IEC Power Cable** to the **BB01 Power Supply**. Continue with Digital In Test if **DUT** has not failed.

Rear Panel Sub Assembly Test - ANALOG CON'T

Audio Fidelity Test

- 1) Press the UTILITY and CHANNEL 7 buttons on the **Known Good ME4 Front Panel Sub-Assembly** and hold these buttons during Step 2. When started in this manner, the unit will enter Factory Test Mode. Please Note Section 1b on the Diagnostic Mode.
- 2) Plug the **IEC Power Cable** into a power source and BB01.

Verify that the front panel LEDs show normal power up message, "DEQ830" on the left side..
After this message "DIAG: <version>" should display on the left side. Verify that the version is the correct, shipping version number for the ME4.

Problems with this inspection indicates that the unit has not entered Factory Test Mode. Unplug the unit and repeat steps 1 and 2.

Problems with the correct version number indicate that the **Known Good ME4 Front Panel** has the incorrect software in it, and that it should be updated to the most recent software.

Failure of this test indicates that this sub-assembly cannot continue further testing. Quickly check the ICs on the Front Panel. If any are hot, or if there is any other indication that the Front Panel may have been damaged (burning smell, etc.), follow QC procedures to check the Front Panel, because the faulty DUT may have damaged the Known Good Front Panel.

- 3) When in Factory Test Mode, pressing PROGRAM will go to next test. Press PROGRAM.

Verify that the front panel LEDs shows first test message "EEPROM" for 1 second.

Verify that the front panel LEDs shows first test message "EEPROM PASS".

Problems with this inspection indicates that the unit is having trouble recognizing the PROGRAM button, or that the EEPROM has failed.

Failure of this test indicates that there is something wrong with the ME4 Known Good Front Panel. Follow procedures to check the Front Panel.

Rear Panel Sub Assembly Test - ANALOG CON'T

- 4) Press PROGRAM until unit displays "A."

Verify that the front panel LEDs shows test messages:

EEPROM -> COL -> ROW -> ALL -> SWITCH -> MIDI

STOP here. IGNORE any messages regarding MIDI, since we are not testing this feature and have not attached the MIDI loopback cable.

- 5) Press PROGRAM.

Verify that the front panel LEDs shows test "A." for AUDIO AP TEST.

- 6) When in Factory Test Mode, the unit will bypass audio so that AP tests can run. Press ENTER on the computer to start the test sequence. It is NOT necessary to enter a serial number since one has not been assigned to the sub-assembly at this stage. Select ALL TESTS at the appropriate menu to run all AP tests. The menu system should be self-explanatory and will guide the user through connection checks. DISREGARD instructions to power-up the DUT, as the DUT has already been powered, and is already in the correct Factory Test Mode.

Verify that the tests run without displaying a "Test Failed" message.

Problems with multiple test failures may be an indication of faulty test connection. Repeat the tests if a problem was found with the cabling. If all the cables have been connected correctly, then the DUT has FAILED.

Failure of this test indicates that this sub-assembly cannot continue further testing.

- 7) Unplug the **IEC Power Cable** to the **BB01 Power Supply**. Then unplug all other cabling to the **DUT**. This is the end of the Rear Panel Sub-Assembly Analog test. Proceed to the Rear Panel Sub-Assembly Digital test.

4) Front Panel Sub Assembly Test

Items Required

- 1 ME4 Front Panel Sub-Assembly (**DUT**)
- 1 Known Good ME4 Rear Panel Sub-Assembly (**Rear Panel**)
- 1 Known Good BB01 Power Supply with internal 4-pin power cable
- 1 24 pin DIL cable for Rear Panel to Front Panel connection.
- 1 Known Good BB01 Power Supply with internal 4-pin power cable
- 1 IEC power cable
- 1 5-pin DIN Male to Male standard MIDI cable

Assembly

- 1) Connect **24 pin DIL cable** from the **DUT J6** to the **Known Good Rear Panel J12**. Be sure that the Pin 1 stripe on the cable is oriented correctly on both sub-assemblies.
- 2) Connect the 4 pin clip-lock power cable from the **BB01 Power Supply** to the **Known Good Rear Panel J13**.
- 3) Connect the **5-pin DIN Male to Male MIDI Cable** from the **MIDI IN jack** to the **MIDI OUT jack**.
- 4) Sub Assembly is ready for testing. Continue with Power Test.

Power Test

- 1) Plug the **IEC Power Cable** into a power source and BB01.

Verify that the front panel LEDs show normal power up message, "DEQ830" on the left side.

Verify that the LEDs do not flicker and are of a consistent brightness.

Problems with this inspection could indicate that the rear panel is not supplying the correct voltage to the **DUT**, OR that the DUT has faulty ICs or other problem. Double check that the 24 pin DIL cable has been installed correctly. If this is not the problem, then the **DUT** has FAILED.

Failure of this test indicates that this sub-assembly cannot continue further testing. Quickly check the ICs on the **DUT** and the **Known Good Rear Panel**. If any are hot, or if there is any other indication that either assembly may have been damaged (burning smell, etc.), follow QC procedures to check the Rear Panel, because the faulty **DUT** may have damaged the Known Good Rear Panel.

- 2) Unplug the **IEC Power Cable** to the **BB01 Power Supply**. Continue with Digital In Test if **DUT** has not failed.

Front Panel Sub Assembly Test CON'T

Front Panel Test

- 1) Press the UTILITY and CHANNEL 7 buttons on the **Known Good ME4 Front Panel Sub-Assembly** and hold these buttons during Step 2. When started in this manner, the unit will enter Factory Test Mode. Please Note Section 1b on the Diagnostic Mode.

- 2) Plug the **IEC Power Cable** into a power source and BB01.

Verify that the front panel LEDs show normal power up message, "DEQ830" on the left side..

After this message "DIAG: <version>" should display on the left side. Verify that the version is the correct, shipping version number for the ME4.

Problems with this inspection indicates that the unit has not entered Factory Test Mode. Unplug the unit and repeat steps 1 and 2.

Problems with the correct version number indicate that the **DUT** has the incorrect software in it, and that it should be updated to the most recent software.

Failure of this test indicates that this sub-assembly cannot continue further testing.

- 3) When in Factory Test Mode, pressing PROGRAM will go to next test. Press PROGRAM.

Verify that the front panel LEDs shows first test message "EEPROM" for 1 second.

Verify that the front panel LEDs shows first test message "EEPROM PASS".

Problems with this inspection indicates that the unit is having trouble recognizing the PROGRAM button, or that the EEPROM has failed.

Failure of this test indicates that this sub-assembly cannot continue further testing.

- 4) Press PROGRAM. This goes to the COL test.

Verify that the front panel LEDs shows "COL" for 1 second.

Verify that the front panel LEDs shows first column.

Verify that all the LEDs are on, that they have a consistent brightness and that they are not flickering.

Problems with this inspection indicates that the unit is problems with its LED display, and that the DUT has FAILED.

Failure of this test indicates that this sub-assembly cannot continue further testing.

Front Panel Sub Assembly Test CON'T

- 5) Turn VALUE knob clockwise. Repeat for left columns 2 through 30 (LVL). Stop this test when the last column on the left side (label: LVL) is displayed.

Verify that the front panel LEDs shows the selected column.

Verify that all the LEDs are on, that they have a consistent brightness and that they are not flickering.

Problems with this inspection indicates that the unit is problems with its LED display, and that the DUT has FAILED.

Problems with the VALUE knob not incrementing the column, indicate that the ENCODER KNOB is failing, and that the DUT has failed.

Failure of this test indicates that this sub-assembly cannot continue further testing.

- 6) Turn VALUE knob clockwise, one position.

Verify that ALL center indicators are on. **Verify** DIGITAL, ANALOG, 48.0, 44.1, REAL TIME ANALYZER indicators.

Verify that all the LEDs are on, that they have a consistent brightness and that they are not flickering.

Problems with this inspection indicates that the unit is problems with its LED display, and that the DUT has FAILED.

Failure of this test indicates that this sub-assembly cannot continue further testing.

- 7) Turn VALUE knob clockwise. Repeat for RIGHT columns 1 through 8. Stop this test when the last column on the left side (label: 8) is displayed.

Verify that the front panel LEDs shows the selected column.

Verify that all the LEDs are on, that they have a consistent brightness and that they are not flickering.

Verify that each number label at the bottom of the column is clearly visible.

Problems with this inspection indicates that the unit is problems with its LED display, and that the DUT has FAILED.

Failure of this test indicates that this sub-assembly cannot continue further testing.

Front Panel Sub Assembly Test CON'T

- 8) Turn VALUE knob clockwise, one position.

Verify that INPUT and OUTPUT indicators are on.

Verify that the FIRST 7- segment digit is on.

Verify that all the LEDs are on, that they have a consistent brightness and that they are not flickering.

Problems with this inspection indicates that the unit is problems with its LED display, and that the DUT has FAILED.

Failure of this test indicates that this sub-assembly cannot continue further testing.

- 9) Turn VALUE knob clockwise, one position.

Verify that STORE and COMPARE indicators are on.

Verify that the SECOND digit is on.

Verify that all the LEDs are on, that they have a consistent brightness and that they are not flickering.

Problems with this inspection indicates that the unit is problems with its LED display, and that the DUT has FAILED.

Failure of this test indicates that this sub-assembly cannot continue further testing.

- 10) Turn VALUE knob clockwise, one position.

Verify that STORE and COMPARE indicators are on.

Verify that the SECOND digit is on.

Verify that all the LEDs are on, that they have a consistent brightness and that they are not flickering.

Problems with this inspection indicates that the unit is problems with its LED display, and that the DUT has FAILED.

Failure of this test indicates that this sub-assembly cannot continue further testing.

Front Panel Sub Assembly Test CON'T

- 11) Turn VALUE knob clockwise, one position. This is the last column.

Verify that PROG, CURVE and DB indicators are on.

Verify that the THIRD digit is on.

Verify that all the LEDs are on, that they have a consistent brightness and that they are not flickering.

Problems with this inspection indicates that the unit is problems with its LED display, and that the DUT has FAILED.

Failure of this test indicates that this sub-assembly cannot continue further testing.

- 12) Press PROGRAM. This goes to the ROW test.

Verify that the front panel LEDs shows "ROW" for 1 second.

Verify that the front panel LEDs shows FIRST row for the left hand side, and that the color is ORANGE.

Verify that the front panel LEDs shows FIRST row for the right hand side, and that the color is GREEN.

Verify that PROG indicator is on, and the color is GREEN.

Verify that all the LEDs are on, that they have a consistent brightness and that they are not flickering.

Problems with this inspection indicates that the unit is problems with its LED display, and that the DUT has FAILED.

Failure of this test indicates that this sub-assembly cannot continue further testing.

- 13) Turn VALUE knob clockwise, one position.

Verify that the front panel LEDs shows SECOND row for the left hand side, and that the color is ORANGE.

Verify that the front panel LEDs shows FIRST row for the right hand side, and that the color is ORANGE.

Verify that OUTPUT, CURVE, and COMPARE indicators are on, and the color is GREEN.

Verify that all the LEDs are on, that they have a consistent brightness and that they are not flickering.

Problems with this inspection indicates that the unit is problems with its LED display, and that the DUT has FAILED.

Failure of this test indicates that this sub-assembly cannot continue further testing.

Front Panel Sub Assembly Test CON'T

- 14) Turn VALUE knob clockwise, one position.

Verify that the front panel LEDs shows THIRD row for the left hand side, and that the color is ORANGE.

Verify that the front panel LEDs shows SECOND row for the right hand side, and that the color is RED.

Verify that INPUT, DB, and STORE indicators are on, and the color is GREEN.

Verify that all the LEDs are on, that they have a consistent brightness and that they are not flickering.

Problems with this inspection indicates that the unit is problems with its LED display, and that the DUT has FAILED.

Failure of this test indicates that this sub-assembly cannot continue further testing.

- 15) Turn VALUE knob clockwise, one position.

Verify that the front panel LEDs shows FOURTH row for the left hand side, and that the color is ORANGE.

Verify that the front panel LEDs shows THIRD row for the right hand side, and that the color is GREEN.

Verify that all the LEDs are on, that they have a consistent brightness and that they are not flickering.

Problems with this inspection indicates that the unit is problems with its LED display, and that the DUT has FAILED.

Failure of this test indicates that this sub-assembly cannot continue further testing.

- 16) Turn VALUE knob clockwise, one position.

Verify that the front panel LEDs shows FIFTH row for the left hand side, and that the color is ORANGE.

Verify that the front panel LEDs shows FOURTH row for the right hand side, and that the color is GREEN.

Verify that all the LEDs are on, that they have a consistent brightness and that they are not flickering.

Problems with this inspection indicates that the unit is problems with its LED display, and that the DUT has FAILED.

Failure of this test indicates that this sub-assembly cannot continue further testing.

Front Panel Sub Assembly Test CON'T

- 17) Turn VALUE knob clockwise, one position.

Verify that the front panel LEDs shows SIXTH row for the left hand side, and that the color is ORANGE.

Verify that the front panel LEDs shows FIFTH row for the right hand side, and that the color is GREEN.

Verify that the decimal places are on in the DIGIT display, and that the color is GREEN.

Verify that all the LEDs are on, that they have a consistent brightness and that they are not flickering.

Problems with this inspection indicates that the unit is problems with its LED display, and that the DUT has FAILED.

Failure of this test indicates that this sub-assembly cannot continue further testing.

- 18) Turn VALUE knob clockwise, one position.

Verify that the front panel LEDs shows SEVENTH row for the left hand side, and that the color is GREEN.

Verify that the front panel LEDs shows SIXTH row for the right hand side, and that the color is GREEN.

Verify that the center segment are on in the DIGIT display, and that the color is GREEN.

Verify that all the LEDs are on, that they have a consistent brightness and that they are not flickering.

Problems with this inspection indicates that the unit is problems with its LED display, and that the DUT has FAILED.

Failure of this test indicates that this sub-assembly cannot continue further testing.

Front Panel Sub Assembly Test CON'T

- 19) Turn VALUE knob clockwise, one position.

Verify that the front panel LEDs shows EIGHTH row for the left hand side, and that the color is ORANGE.

Verify that the front panel LEDs shows SEVENTH row for the right hand side, and that the color is GREEN.

Verify that the upper left segment are on in the DIGIT display, and that the color is GREEN.

Verify that all the LEDs are on, that they have a consistent brightness and that they are not flickering.

Problems with this inspection indicates that the unit is problems with its LED display, and that the DUT has FAILED.

Failure of this test indicates that this sub-assembly cannot continue further testing.

- 20) Turn VALUE knob clockwise, one position.

Verify that the front panel LEDs shows NINTH row for the left hand side, and that the color is ORANGE.

Verify that the front panel LEDs shows EIGHTH row for the right hand side, and that the color is GREEN.

Verify that the lower left segment are on in the DIGIT display, and that the color is GREEN.

Verify that the REAL TIME ANALYZER indicator is on and that the color is GREEN.

Verify that all the LEDs are on, that they have a consistent brightness and that they are not flickering.

Problems with this inspection indicates that the unit is problems with its LED display, and that the DUT has FAILED.

Failure of this test indicates that this sub-assembly cannot continue further testing.

Front Panel Sub Assembly Test CON'T

21) Turn VALUE knob clockwise, one position.

Verify that the front panel LEDs shows TENTH row for the left hand side, and that the color is ORANGE.

Verify that the front panel LEDs shows NINTH row for the right hand side, and that the color is ORANGE.

Verify that the bottom segment are on in the DIGIT display, and that the color is GREEN.

Verify that the 44.1 indicator is on and that the color is GREEN.

Verify that all the LEDs are on, that they have a consistent brightness and that they are not flickering.

Problems with this inspection indicates that the unit is problems with its LED display, and that the DUT has FAILED.

Failure of this test indicates that this sub-assembly cannot continue further testing.

22) Turn VALUE knob clockwise, one position.

Verify that the front panel LEDs shows ELEVENTH row for the left hand side, and that the color is ORANGE.

Verify that the front panel LEDs shows TENTH row for the right hand side, and that the color is ORANGE.

Verify that the bottom right segment are on in the DIGIT display, and that the color is GREEN.

Verify that the 44.1 indicator is on and that the color is GREEN.

Verify that all the LEDs are on, that they have a consistent brightness and that they are not flickering.

Problems with this inspection indicates that the unit is problems with its LED display, and that the DUT has FAILED.

Failure of this test indicates that this sub-assembly cannot continue further testing.

Front Panel Sub Assembly Test CON'T

23) Turn VALUE knob clockwise, one position.

Verify that the front panel LEDs shows TWELFTH row for the left hand side, and that the color is ORANGE.

Verify that the front panel LEDs shows ELEVENTH row for the right hand side, and that the color is ORANGE.

Verify that the top right segment are on in the DIGIT display, and that the color is GREEN.

Verify that the ANALOG indicator is on and that the color is GREEN.

Verify that all the LEDs are on, that they have a consistent brightness and that they are not flickering.

Problems with this inspection indicates that the unit is problems with its LED display, and that the DUT has FAILED.

Failure of this test indicates that this sub-assembly cannot continue further testing.

24) Turn VALUE knob clockwise, one position. This is the last row.

Verify that the front panel LEDs shows THIRTEENTH row for the left hand side, and that the color is ORANGE.

Verify that the front panel LEDs shows TWELFTH row for the right hand side, and that the color is RED.

Verify that the top segment are on in the DIGIT display, and that the color is GREEN.

Verify that the DIGITAL indicator is on and that the color is GREEN.

Verify that all the LEDs are on, that they have a consistent brightness and that they are not flickering.

Problems with this inspection indicates that the unit is problems with its LED display, and that the DUT has FAILED.

Failure of this test indicates that this sub-assembly cannot continue further testing.

Front Panel Sub Assembly Test CON'T

25) Press PROGRAM. This goes to the ALL led test.

DO NOT RUN THIS TEST FOR MORE THAN ONE MINUTE. EXCESSIVE POWER USAGE WILL CAUSE POWER SUPPLY TO OVERHEAT.

Verify that the front panel LEDs shows "ALL" for 1 second.

Verify that all the LEDs are on, that they have a consistent brightness and that they are not flickering.

Problems with this inspection indicates that the unit is problems with its LED display, and that the DUT has FAILED.

Failure of this test indicates that this sub-assembly cannot continue further testing.

26) Press PROGRAM. This goes to the SWITCH test.

Verify that the front panel LEDs shows "SWITCH" for 1 second.

27) Press Band Buttons 0-29, LVL.

Verify that while the button is held, the display shows "BND X" where X is the band number. The first band button is "0". When pressing the LVL button, the band number shown is "30"

Verify that the display does NOT show "ERROR" or "COMBO"

Problems with this inspection indicates that the unit has problems with its switches, and that the DUT has FAILED.

Failure of this test indicates that this sub-assembly cannot continue further testing.

28) Press CHANNEL Buttons 1-8

Verify that while the button is held, the display shows "CHN X" where X is the channel number. The first channel button is "0". The last channel button is "7".

Verify that the display does NOT show "ERROR" or "COMBO"

Problems with this inspection indicates that the unit has problems with its switches, and that the DUT has FAILED.

Failure of this test indicates that this sub-assembly cannot continue further testing.

Front Panel Sub Assembly Test CON'T

- 29) Press REAL TIME ANALYZER, INPUT/OUTPUT, ALL, BYPASS, LINK, STORE, COMPARE, UTILITY, SAVE CURVE, and PUSH TO ENTER Buttons.

Verify that while the button is the display shows its name or an abbreviated name.

Verify that the display does NOT show "ERROR" or "COMBO"

Problems with this inspection indicates that the unit has problems with its switches, and that the DUT has FAILED.

Failure of this test indicates that this sub-assembly cannot continue further testing.

- 30) Press PROGRAM. This runs the MIDI test.

Verify that the front panel LEDs shows test "MIDI" for 1 second.

Verify that display shows "MIDI PASS".

Problems with this inspection indicate that there is a MIDI electrical or cabling problem. Try adjusting or replacing the MIDI Cable, unplug the IEC Cable and repeat steps 1 through 5. If the error message still shows after adjusting the cable, then the DUT has FAILED.

Failure of this test indicates that this sub-assembly cannot continue further testing.

- 31) Press PROGRAM twice. This configures the unit for RESET. There is no need to run the audio test or the digital audio test for the rear panel at this time.

Verify that the front panel LEDs shows test messages:

MIDI -> A. -> DIG A. -> RESET

Stop here.

Verify that the front panel LEDs shows test "RESET".

Front Panel Sub Assembly Test CON'T

- 32) Press Press "PUSH TO ENTER" encoder button. This starts the reset process.

Verify that the front panel seven segment displays count from "00" to "99." When the display reaches "99" the reset procedure is done.

Problems with the display not starting to count indicate failure of the encoder button, and that the **DUT** has failed.

Problems with the display not reach "99" indicate that the EEPROM has encountered an error and that the **DUT** has failed.

Failure of this test indicates that this sub-assembly cannot continue further testing.

- 33) Press PROGRAM. This finishes the test.

Verify that the front panel LEDs shows test "DONE".

- 34) Unplug the **IEC Power Cable** to the **BB01 Power Supply**. Then unplug all other cabling to the **DUT**. This is the end of the Front Panel Sub-Assembly electrical test.

5) Assembly QC

The manufacturer is responsible for QC during the assembly of the unit, including all procedures to ensure that the final unit is clean and free of marks, scratches, and smudges.

Before the cover is screwed on

The following suggested check is intended as a rough guide for inspecting the unit before securing the cover of the unit:

- 1) Check all components for quality such as scratches, marks, deformities in the metal work, etc. Check the front lens for scratches, smudges, debris, and other defects which might cause imperfect viewing of the LEDs behind it.
- 2) Check all PCB mounting screws. All audio jacks should be secured to the rear panel with BOTH a washer AND nut.
- 3) Check all cabling for correct orientation and placement. Make sure the cabling is secure and will not rattle when the unit is moved or turned upside down
- 4) Check the fit of all mechanical parts for gaps between pieces that should fit tightly together.
- 5) Check sub-panel assembly for proper interaction with the front panel such as switch mechanical operation and lens fit. Make sure the lens has been properly glued and does not extend beyond the front panel.
- 6) Check the silkscreen on the front and rear of the unit for correctness of color and content against the latest design. Make sure that all artwork is clear and correctly aligned.
- 7) Quickly plug the unit into an Alesis P3 type power supply to ensure LEDs light and proper startup screen appears. While the LEDs are on, check to make sure that the front lens is clear and working as anticipated.

After the cover has been screwed on

The following suggested check is intended as a rough guide for inspecting the unit after securing the cover of the unit:

- 1) Check all components for quality such as scratches, marks, deformities in the metal work, etc. Check the front lens for scratches, smudges and other defects which might cause imperfect viewing of the LEDs behind it.
- 2) Check for all the external screws. Item count to be provided by manufacturer.
- 3) Check the fit of all mechanical parts for gaps between pieces that should fit tightly together.
- 4) Rotate the unit in all directions and listen for any loose parts which may rattle inside the box. Listen to make sure the cabling has been properly secured.
- 5) Check to make sure that the proper serial number has been attached to the unit.
- 6) Clean the unit from all debris and marks caused by handling the unit.

6) Final Assembly QC

Items Required

- 1 ME4 (DUT)
- 1 IEC power cable
- 1 ADAT Optical cable
- 1 5-pin DIN Male to Male standard MIDI cable

Assembly

- 1) Connect one end of the **ADAT Optical** cable from **DUT Optical OUT** to **DUT Optical IN**.
- 2) Connect the **5-pin DIN Male to Male MIDI Cable** from the **MIDI IN jack** to the **MIDI OUT jack**.
- 3) Unit is ready for testing. Continue with Power Test.

Power Test

- 1) Plug the **IEC Power Cable** into a power source and **DUT IEC Power In** connector.

Verify that the front panel LEDs show normal power up message, "DEQ830" on the left side.

Verify that the LEDs do not flicker and are of a consistent brightness.

Problems with this inspection indicates that the unit has been incorrectly assembled. Double check that the IEC cable has been properly plugged in. If this is not the problem, then the DUT has FAILED.

Failure of this test indicates that this unit cannot continue further testing.

- 2) Unplug the **IEC Power Cable** to the **DUT IEC Power In**. Continue with System Test if **DUT** has not failed.

System Test

- 1) Press the UTILITY and CHANNEL 7 buttons on the **Known Good ME4 Front Panel Sub-Assembly** and hold these buttons during Step 2. When started in this manner, the unit will enter Factory Test Mode. Please Note Section 1b on the Diagnostic Mode.

Final Assembly System Test CON'T

- 2) Plug the **IEC Power Cable** into a power source and BB01.

Verify that the front panel LEDs show normal power up message, "DEQ830" on the left side..
After this message "DIAG: <version>" should display on the left side. Verify that the version is the correct, shipping version number for the ME4.

Problems with this inspection indicates that the unit has not entered Factory Test Mode. Unplug the unit and repeat steps 1 and 2.

Problems with the correct version number indicate that the **DUT** has the incorrect software in it, and that it should be updated to the most recent software.

Problems with this inspection indicates that the unit has been incorrectly assembled. Double check that the IEC cable has been properly plugged in. If this is not the problem, then the DUT has FAILED.

- 3) When in Factory Test Mode, pressing PROGRAM will go to next test. Press PROGRAM.

Verify that the front panel LEDs shows first test message "EEPROM" for 1 second.

Verify that the front panel LEDs shows first test message "EEPROM PASS".

Problems with this inspection indicates that the unit is having trouble recognizing the PROGRAM button, or that the EEPROM has failed.

Failure of this test indicates that this sub-assembly cannot continue further testing.

- 4) Press PROGRAM. This goes to the COL test.

Verify that the front panel LEDs shows "COL" for 1 second.

Verify that the front panel LEDs shows first column.

Verify that all the LEDs are on, that they have a consistent brightness and that they are not flickering.

Problems with this inspection indicates that the unit is problems with its LED display, and that the DUT has FAILED.

Failure of this test indicates that this sub-assembly cannot continue further testing.

Final Assembly System Test CON'T

- 5) Turn VALUE knob clockwise. Repeat for left columns 2 through 30 (LVL). Stop this test when the last column on the left side (label: LVL) is displayed.

Verify that the front panel LEDs shows the selected column.

Verify that all the LEDs are on, that they have a consistent brightness and that they are not flickering.

Problems with this inspection indicates that the unit is problems with its LED display, and that the DUT has FAILED.

Problems with the VALUE knob not incrementing the column, indicate that the ENCODER KNOB is failing, and that the DUT has failed.

Failure of this test indicates that this sub-assembly cannot continue further testing.

- 6) Turn VALUE knob clockwise, one position.

Verify that ALL center indicators are on. **Verify** DIGITAL, ANALOG, 48.0, 44.1, REAL TIME ANALYZER indicators.

Verify that all the LEDs are on, that they have a consistent brightness and that they are not flickering.

Problems with this inspection indicates that the unit is problems with its LED display, and that the DUT has FAILED.

Failure of this test indicates that this sub-assembly cannot continue further testing.

- 7) Turn VALUE knob clockwise. Repeat for RIGHT columns 1 through 8. Stop this test when the last column on the left side (label: 8) is displayed.

Verify that the front panel LEDs shows the selected column.

Verify that all the LEDs are on, that they have a consistent brightness and that they are not flickering.

Verify that each number label at the bottom of the column is clearly visible.

Problems with this inspection indicates that the unit is problems with its LED display, and that the DUT has FAILED.

Failure of this test indicates that this sub-assembly cannot continue further testing.

Final Assembly System Test CON'T

- 8) Turn VALUE knob clockwise, one position.

Verify that INPUT and OUTPUT indicators are on.

Verify that the FIRST 7- segment digit is on.

Verify that all the LEDs are on, that they have a consistent brightness and that they are not flickering.

Problems with this inspection indicates that the unit is problems with its LED display, and that the DUT has FAILED.

Failure of this test indicates that this sub-assembly cannot continue further testing.

- 9) Turn VALUE knob clockwise, one position.

Verify that STORE and COMPARE indicators are on.

Verify that the SECOND digit is on.

Verify that all the LEDs are on, that they have a consistent brightness and that they are not flickering.

Problems with this inspection indicates that the unit is problems with its LED display, and that the DUT has FAILED.

Failure of this test indicates that this sub-assembly cannot continue further testing.

- 10) Turn VALUE knob clockwise, one position.

Verify that STORE and COMPARE indicators are on.

Verify that the SECOND digit is on.

Verify that all the LEDs are on, that they have a consistent brightness and that they are not flickering.

Problems with this inspection indicates that the unit is problems with its LED display, and that the DUT has FAILED.

Failure of this test indicates that this sub-assembly cannot continue further testing.

Final Assembly System Test CON'T

- 11) Turn VALUE knob clockwise, one position. This is the last column.

Verify that PROG, CURVE and DB indicators are on.

Verify that the THIRD digit is on.

Verify that all the LEDs are on, that they have a consistent brightness and that they are not flickering.

Problems with this inspection indicates that the unit is problems with its LED display, and that the DUT has FAILED.

Failure of this test indicates that this sub-assembly cannot continue further testing.

- 12) Press PROGRAM. This goes to the ROW test.

Verify that the front panel LEDs shows "ROW" for 1 second.

Verify that the front panel LEDs shows FIRST row for the left hand side, and that the color is ORANGE.

Verify that the front panel LEDs shows FIRST row for the right hand side, and that the color is GREEN.

Verify that PROG indicator is on, and the color is GREEN.

Verify that all the LEDs are on, that they have a consistent brightness and that they are not flickering.

Problems with this inspection indicates that the unit is problems with its LED display, and that the DUT has FAILED.

Failure of this test indicates that this sub-assembly cannot continue further testing.

- 13) Turn VALUE knob clockwise, one position.

Verify that the front panel LEDs shows SECOND row for the left hand side, and that the color is ORANGE.

Verify that the front panel LEDs shows FIRST row for the right hand side, and that the color is ORANGE.

Verify that OUTPUT, CURVE, and COMPARE indicators are on, and the color is GREEN.

Verify that all the LEDs are on, that they have a consistent brightness and that they are not flickering.

Problems with this inspection indicates that the unit is problems with its LED display, and that the DUT has FAILED.

Failure of this test indicates that this sub-assembly cannot continue further testing.

Final Assembly System Test CON'T

- 14) Turn VALUE knob clockwise, one position.

Verify that the front panel LEDs shows THIRD row for the left hand side, and that the color is ORANGE.

Verify that the front panel LEDs shows SECOND row for the right hand side, and that the color is RED.

Verify that INPUT, DB, and STORE indicators are on, and the color is GREEN.

Verify that all the LEDs are on, that they have a consistent brightness and that they are not flickering.

Problems with this inspection indicates that the unit is problems with its LED display, and that the DUT has FAILED.

Failure of this test indicates that this sub-assembly cannot continue further testing.

- 15) Turn VALUE knob clockwise, one position.

Verify that the front panel LEDs shows FOURTH row for the left hand side, and that the color is ORANGE.

Verify that the front panel LEDs shows THIRD row for the right hand side, and that the color is GREEN.

Verify that all the LEDs are on, that they have a consistent brightness and that they are not flickering.

Problems with this inspection indicates that the unit is problems with its LED display, and that the DUT has FAILED.

Failure of this test indicates that this sub-assembly cannot continue further testing.

- 16) Turn VALUE knob clockwise, one position.

Verify that the front panel LEDs shows FIFTH row for the left hand side, and that the color is ORANGE.

Verify that the front panel LEDs shows FOURTH row for the right hand side, and that the color is GREEN.

Verify that all the LEDs are on, that they have a consistent brightness and that they are not flickering.

Problems with this inspection indicates that the unit is problems with its LED display, and that the DUT has FAILED.

Failure of this test indicates that this sub-assembly cannot continue further testing.

Final Assembly System Test CON'T

17) Turn VALUE knob clockwise, one position.

Verify that the front panel LEDs shows SIXTH row for the left hand side, and that the color is ORANGE.

Verify that the front panel LEDs shows FIFTH row for the right hand side, and that the color is GREEN.

Verify that the decimal places are on in the DIGIT display, and that the color is GREEN.

Verify that all the LEDs are on, that they have a consistent brightness and that they are not flickering.

Problems with this inspection indicates that the unit is problems with its LED display, and that the DUT has FAILED.

Failure of this test indicates that this sub-assembly cannot continue further testing.

18) Turn VALUE knob clockwise, one position.

Verify that the front panel LEDs shows SEVENTH row for the left hand side, and that the color is GREEN.

Verify that the front panel LEDs shows SIXTH row for the right hand side, and that the color is GREEN.

Verify that the center segment are on in the DIGIT display, and that the color is GREEN.

Verify that all the LEDs are on, that they have a consistent brightness and that they are not flickering.

Problems with this inspection indicates that the unit is problems with its LED display, and that the DUT has FAILED.

Failure of this test indicates that this sub-assembly cannot continue further testing.

Final Assembly System Test CON'T

19) Turn VALUE knob clockwise, one position.

Verify that the front panel LEDs shows EIGHTH row for the left hand side, and that the color is ORANGE.

Verify that the front panel LEDs shows SEVENTH row for the right hand side, and that the color is GREEN.

Verify that the upper left segment are on in the DIGIT display, and that the color is GREEN.

Verify that all the LEDs are on, that they have a consistent brightness and that they are not flickering.

Problems with this inspection indicates that the unit is problems with its LED display, and that the DUT has FAILED.

Failure of this test indicates that this sub-assembly cannot continue further testing.

20) Turn VALUE knob clockwise, one position.

Verify that the front panel LEDs shows NINTH row for the left hand side, and that the color is ORANGE.

Verify that the front panel LEDs shows EIGHTH row for the right hand side, and that the color is GREEN.

Verify that the lower left segment are on in the DIGIT display, and that the color is GREEN.

Verify that the REAL TIME ANALYZER indicator is on and that the color is GREEN.

Verify that all the LEDs are on, that they have a consistent brightness and that they are not flickering.

Problems with this inspection indicates that the unit is problems with its LED display, and that the DUT has FAILED.

Failure of this test indicates that this sub-assembly cannot continue further testing.

Final Assembly System Test CON'T

21) Turn VALUE knob clockwise, one position.

Verify that the front panel LEDs shows TENTH row for the left hand side, and that the color is ORANGE.

Verify that the front panel LEDs shows NINTH row for the right hand side, and that the color is ORANGE.

Verify that the bottom segment are on in the DIGIT display, and that the color is GREEN.

Verify that the 44.1 indicator is on and that the color is GREEN.

Verify that all the LEDs are on, that they have a consistent brightness and that they are not flickering.

Problems with this inspection indicates that the unit is problems with its LED display, and that the DUT has FAILED.

Failure of this test indicates that this sub-assembly cannot continue further testing.

22) Turn VALUE knob clockwise, one position.

Verify that the front panel LEDs shows ELEVENTH row for the left hand side, and that the color is ORANGE.

Verify that the front panel LEDs shows TENTH row for the right hand side, and that the color is ORANGE.

Verify that the bottom right segment are on in the DIGIT display, and that the color is GREEN.

Verify that the 44.1 indicator is on and that the color is GREEN.

Verify that all the LEDs are on, that they have a consistent brightness and that they are not flickering.

Problems with this inspection indicates that the unit is problems with its LED display, and that the DUT has FAILED.

Failure of this test indicates that this sub-assembly cannot continue further testing.

Final Assembly System Test CON'T

23) Turn VALUE knob clockwise, one position.

Verify that the front panel LEDs shows TWELFTH row for the left hand side, and that the color is ORANGE.

Verify that the front panel LEDs shows ELEVENTH row for the right hand side, and that the color is ORANGE.

Verify that the top right segment are on in the DIGIT display, and that the color is GREEN.

Verify that the ANALOG indicator is on and that the color is GREEN.

Verify that all the LEDs are on, that they have a consistent brightness and that they are not flickering.

Problems with this inspection indicates that the unit is problems with its LED display, and that the DUT has FAILED.

Failure of this test indicates that this sub-assembly cannot continue further testing.

24) Turn VALUE knob clockwise, one position. This is the last row.

Verify that the front panel LEDs shows THIRTEENTH row for the left hand side, and that the color is ORANGE.

Verify that the front panel LEDs shows TWELFTH row for the right hand side, and that the color is RED.

Verify that the top segment are on in the DIGIT display, and that the color is GREEN.

Verify that the DIGITAL indicator is on and that the color is GREEN.

Verify that all the LEDs are on, that they have a consistent brightness and that they are not flickering.

Problems with this inspection indicates that the unit is problems with its LED display, and that the DUT has FAILED.

Failure of this test indicates that this sub-assembly cannot continue further testing.

Final Assembly System Test CON'T

- 25) Press PROGRAM. This goes to the ALL led test.

DO NOT RUN THIS TEST FOR MORE THAN ONE MINUTE. EXCESSIVE POWER USAGE WILL CAUSE POWER SUPPLY TO OVERHEAT.

Verify that the front panel LEDs shows "ALL" for 1 second.

Verify that all the LEDs are on, that they have a consistent brightness and that they are not flickering.

Problems with this inspection indicates that the unit is problems with its LED display, and that the DUT has FAILED.

Failure of this test indicates that this sub-assembly cannot continue further testing.

- 26) Press PROGRAM. This goes to the SWITCH test.

Verify that the front panel LEDs shows "SWITCH" for 1 second.

- 27) Press Band Buttons 0-29, LVL.

Verify that while the button is held, the display shows "BND X" where X is the band number. The first band button is "0". When pressing the LVL button, the band number shown is "30"

Verify that the display does NOT show "ERROR" or "COMBO"

Problems with this inspection indicates that the unit has problems with its switches, and that the DUT has FAILED.

Failure of this test indicates that this sub-assembly cannot continue further testing.

- 28) Press CHANNEL Buttons 1-8

Verify that while the button is held, the display shows "CHN X" where X is the channel number. The first channel button is "0". The last channel button is "7".

Verify that the display does NOT show "ERROR" or "COMBO"

Problems with this inspection indicates that the unit has problems with its switches, and that the DUT has FAILED.

Failure of this test indicates that this sub-assembly cannot continue further testing.

Final Assembly System Test CON'T

- 29) Press REAL TIME ANALYZER, INPUT/OUTPUT, ALL, BYPASS, LINK, STORE, COMPARE, UTILITY, SAVE CURVE, and PUSH TO ENTER Buttons.

Verify that while the button is the display shows its name or an abbreviated name.

Verify that the display does NOT show "ERROR" or "COMBO"

Problems with this inspection indicates that the unit has problems with its switches, and that the DUT has FAILED.

Failure of this test indicates that this sub-assembly cannot continue further testing.

- 30) Press PROGRAM. This runs the MIDI test.

Verify that the front panel LEDs shows test "MIDI" for 1 second.

Verify that display shows "MIDI PASS".

Problems with this inspection indicate that there is a MIDI electrical or cabling problem. Try adjusting or replacing the MIDI Cable, unplug the IEC Cable and repeat steps 1 through 5. If the error message still shows after adjusting the cable, then the DUT has FAILED.

Failure of this test indicates that this sub-assembly cannot continue further testing.

- 31) Press PROGRAM once to advance to the audio ("A.") test.

- 32) Connect one end of the **ADAT Optical** cable from **DUT Optical OUT** to **DUT Optical IN**.

Verify that the source indicator in the middle of the front panel shows the audio switching from "ANALOG" to "DIGITAL", and that the "DIGITAL" indicator stays lit solid.

Problems with this inspection indicate that there is a optical audio problem. Try adjusting or replacing the ADAT Optical Cable, unplug the IEC Cable and repeat steps 1 through 6. Also, verify that the Known Good Front Panel has been properly RESET as described in Section 7 "RESET". If after resetting the Front Panel and adjusting the loopback cable, the unit does not switch to "DIGITAL" then there is a problem with ADAT Optical and the DUT has FAILED.

Failure of this test indicates that this sub-assembly cannot continue further testing.

Final Assembly System Test CON'T

- 33) Press PROGRAM once to advance to the DIG AUDIO test. The analog audio test is not essential for this test.

Verify that the front panel LEDs shows test messages:

MIDI -> A. -> DIG A.

Stop here.

Verify that the front panel LEDs shows test "DIG A." for 1 second.

Verify that display shows "DIG PASS".

Problems with this inspection indicate that there is a ADAT Optical electrical or cabling problem. Try adjusting or replacing the ADAT Optical Cable, unplug the IEC Cable and repeat steps 1 through 6. If the error message still shows after adjusting the cable, then the DUT has FAILED.

Failure of this test indicates that this sub-assembly cannot continue further testing.

- 34) Press PROGRAM. This configures the unit for RESET.

Verify that the front panel LEDs shows test "RESET".

- 35) Press "PUSH TO ENTER" encoder button. This starts the reset process.

Verify that the front panel seven segment displays count from "00" to "99." When the display reaches "99" the reset procedure is done.

Problems with the display not starting to count indicate failure of the encoder button, and that the **DUT** has failed.

Problems with the display not reach "99" indicate that the EEPROM has encountered an error and that the **DUT** has failed.

Failure of this test indicates that this sub-assembly cannot continue further testing.

- 36) Press PROGRAM. This finishes the test.

Verify that the front panel LEDs shows test "DONE".

- 37) Unplug the **IEC Power Cable** to the **BB01 Power Supply**. Then unplug all other cabling to the **DUT**. This is the end of the Front Panel Sub-Assembly electrical test.

7) Reset

Before the DUT is packaged, the unit should be reset to factory defaults. This resets the EEPROM persistent memory.

Items Required

- 1 ME4 Assembled Unit (**DUT**) which has PASSED Final Assembly QC
- 1 IEC Power Cable

Reset

- 1) Press the UTILITY and CHANNEL 7 buttons on the **DUT** and hold these buttons during Step 2. When started in this manner, the unit will enter Factory Test Mode. Please Note Section 1b on the Diagnostic Mode.
- 2) Plug the **IEC Power Cable** into a power source and **DUT IEC Power In**.

Verify that the front panel LEDs show normal power up message, "DEQ830" on the left side. After this message "DIAG" should display on the left side.

Problems with this inspection indicates that the unit has not entered Factory Test Mode. Unplug the unit and repeat steps 1 and 2.

Failure of this test indicates that this unit cannot continue further testing.
- 3) Press PROGRAM 8 times (until **DUT** displays "RESET"). Note test order:

DIAG -> EEPROM -> COL -> ROW -> ALL -> MIDI -> A. -> DIG A. ->
RESET -> DONE

Verify that the DUT shows "RESET" on the left side.
- 4) Press "PUSH TO ENTER" encoder button.

Verify that the DUT shows "RESET COMPLETE" on the left side.

Problems with this inspection indicates that the unit has not entered reset. Unplug the unit and repeat steps 1-3. Continued failure of this test indicates a problem with the unit, and the DUT has FAILED.

Failure of this test indicates that this DUT has not RESET.
- 5) Unplug the **IEC Power Cable** to the **DUT IEC Power In**. This is the end of the system reset procedure.

6

5

4

3

2

1

14 DBU IN	-10dBV IN
NOM 1.73Vrms	0.604V
18.93dBu	0.33Vrms
9.31VTP-P	0.13Vrms
0.83Vrms	8.48dBu
0.29Vrms	10.30VTP-P
	5.83dBu
	2.00Vrms

DIFF INPUT	
-3.25dB	
18.93dBu	8.48dBu
9.31VTP-P	5.83dBu
0.83Vrms	2.00Vrms

+4/-10 SWITCH	
-10.45dB	0dB
18.93dBu	5.23dBu
9.31VTP-P	4.00VTP-P
0.83Vrms	1.41Vrms

UNBAL -> BAL	
+6.02dB	
18.93dBu	5.23dBu
9.31VTP-P	4.00VTP-P
0.83Vrms	1.41Vrms

ADC CONVERSION	
0dBFS	
18.93dBu	5.23dBu
9.31VTP-P	4.00VTP-P
0.83Vrms	1.41Vrms

REVISION RECORD		
LR	ECO NO.	APPROVED
DATE		

D

CH 1 IN

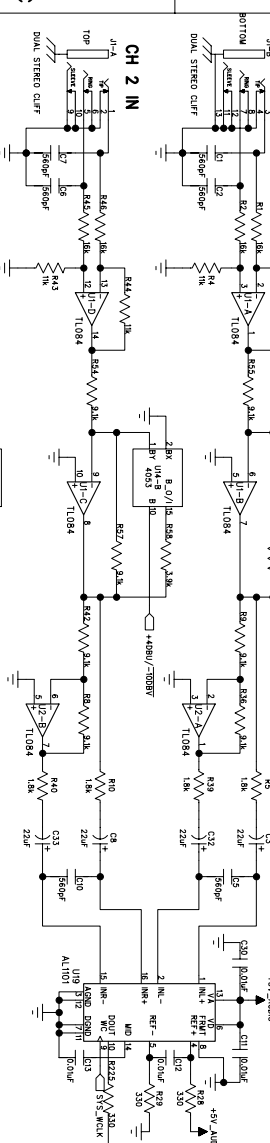

C

CH 2 IN

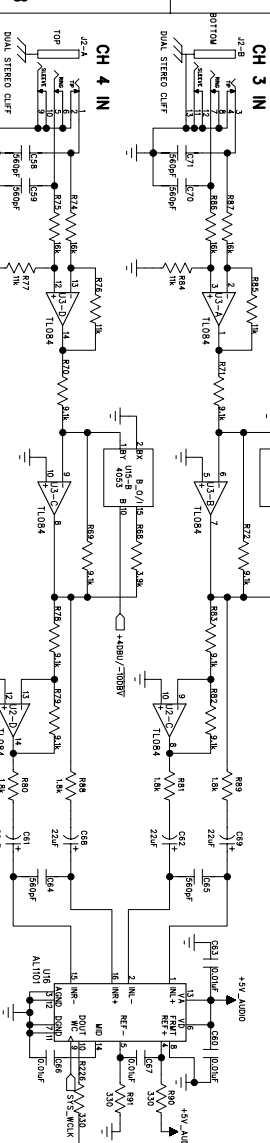

B

CH 3 IN



A

CH 4 IN



COMPANY: ALESIS

TITLE: ME4 - DIGITAL GRAPHIC EQ REAR PANEL PCB

DATE: 11/28/02

ASSY NUMBER: 9-40-0284-3

FILENAME: ME4RP301A.SCH

SCALE: SHEET: 1 OF 5

DRW: MEYER/MARESH

RELEASED:

REV: C

SIZE: C

A

B

C

D

REVISION RECORD		
LR	ECO NO.	APPROVED DATE

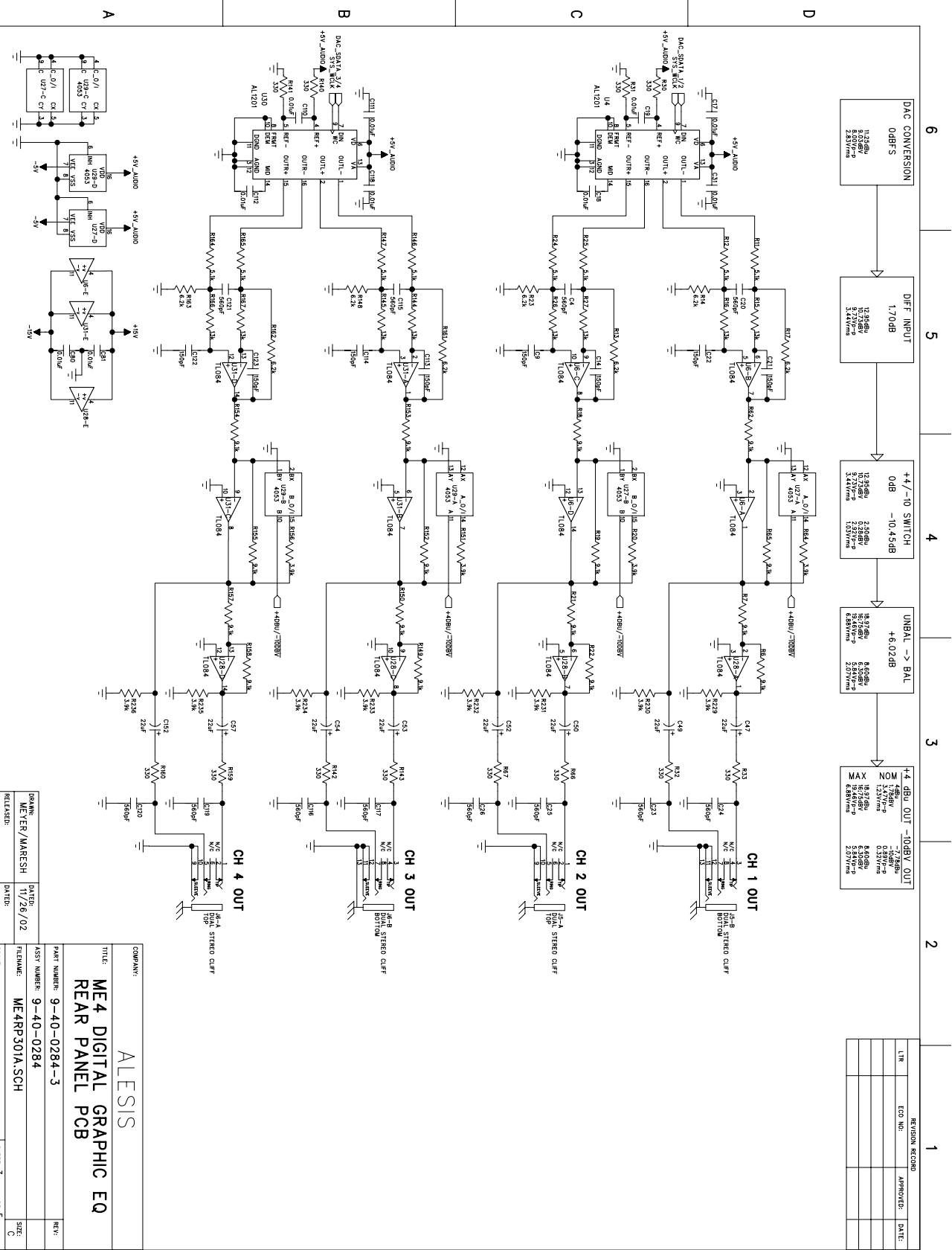

COMPANY: ALESIS	
TITLE: ME4 DIGITAL GRAPHIC EQ REAR PANEL PCB	
PART NUMBER: 9-40-0284-3	REV:
ASSY NUMBER: 9-40-0284	
FILENAME: ME4RP301A.SCH	SIZE: C
DATE: 1/28/02	
DRAWN: MEYER/MARESH	
RELEASED:	
SCALE:	SHEET: 3 OF 5

REVISION RECORD		
LT#	ECO NO.	APPROVED DATE

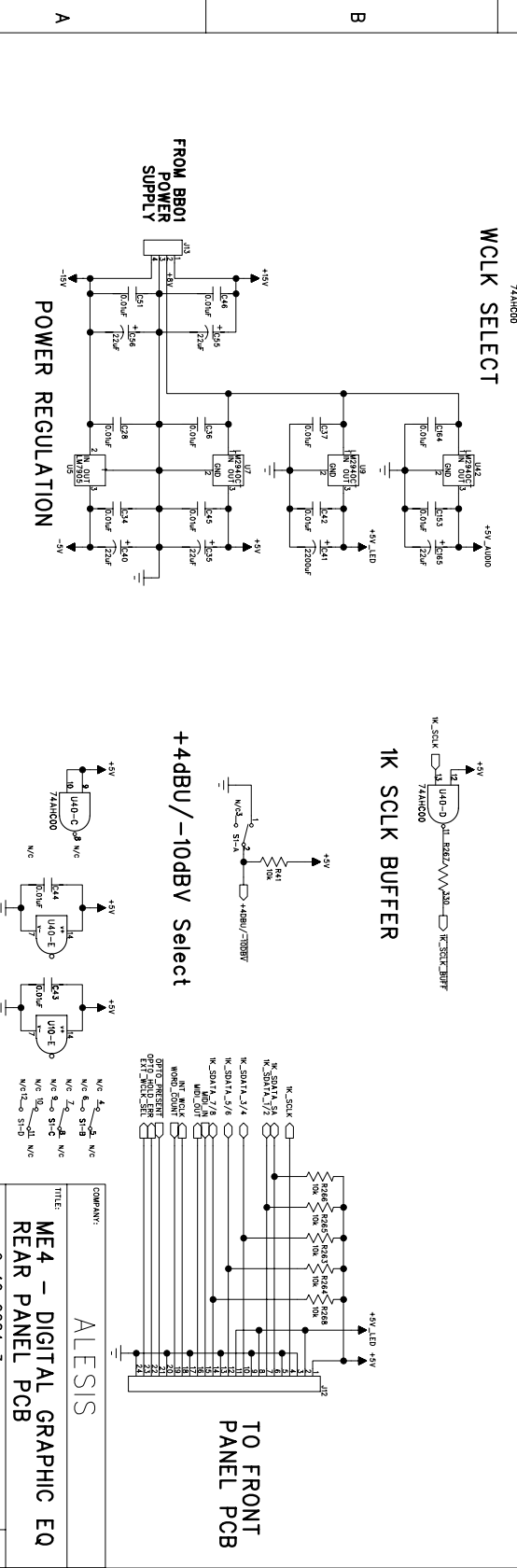
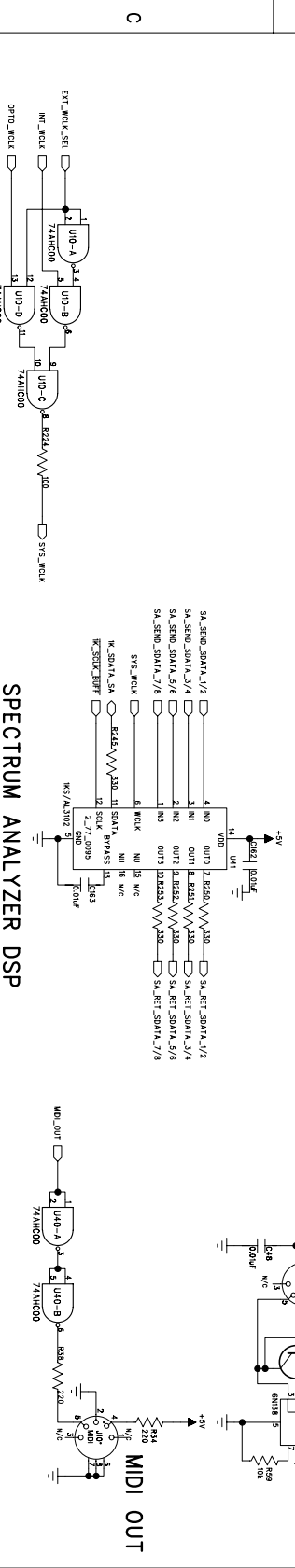
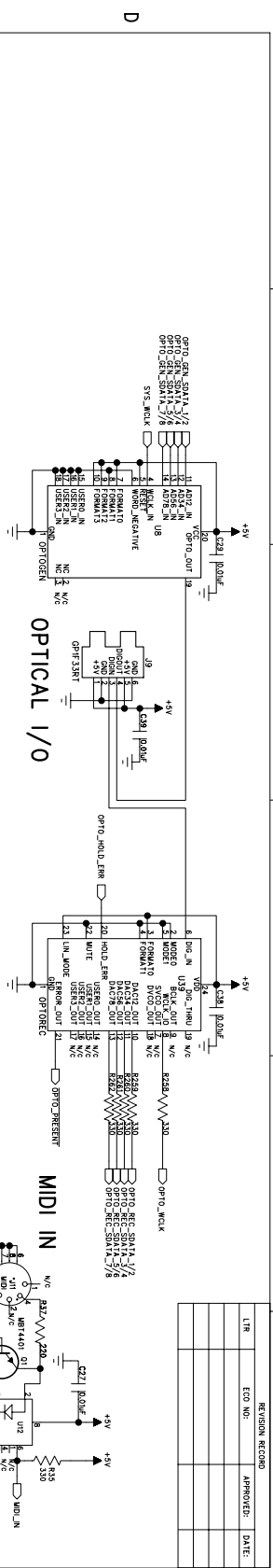

FROM BR01 POWER SUPPLY

POWER REGULATION

+4dB/-10dBV Select

1K SCLK BUFFER

SPECTRUM ANALYZER DSP

WCLK SELECT

MIDI IN

MIDI OUT

TO FRONT PANEL PCB

TO REAR PANEL PCB

ALESIS

ME4 - DIGITAL GRAPHIC EQ REAR PANEL PCB

COMPANY: ALESIS
 TITLE: ME4 - DIGITAL GRAPHIC EQ REAR PANEL PCB
 PART NUMBER: 9-40-0284-3
 ASSY NUMBER: 9-40-0284
 FILENAME: ME4RP301A.SCH
 DRAWN: MEYER/MARESH
 DATED: 1/28/02
 RELEASED: DATED: SCALE: SHEET: 5 OF 5

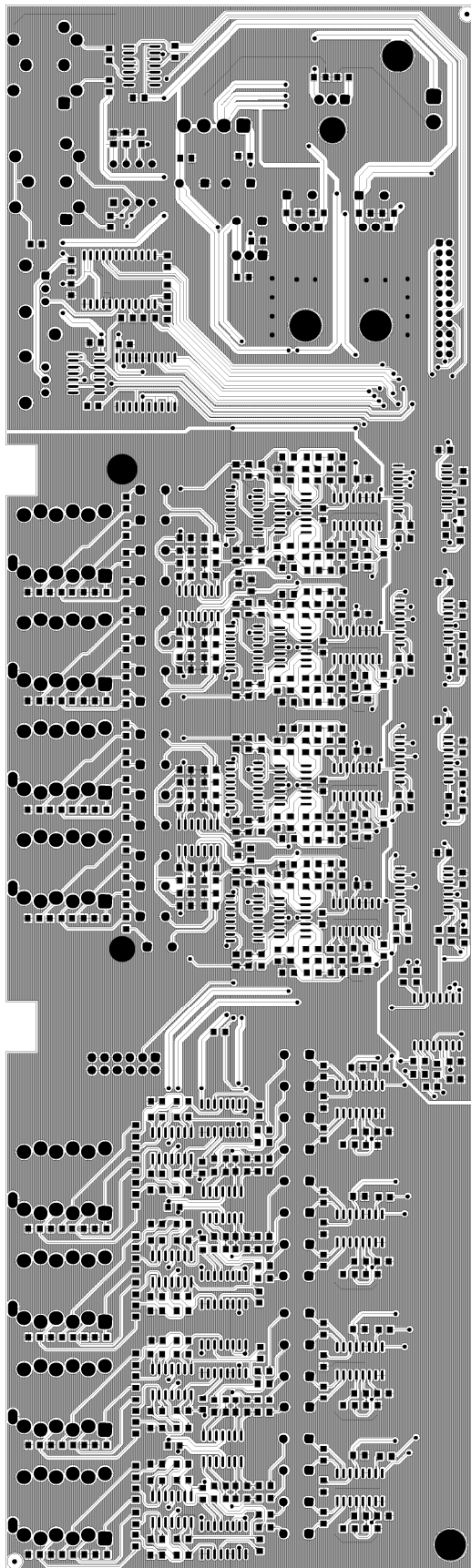

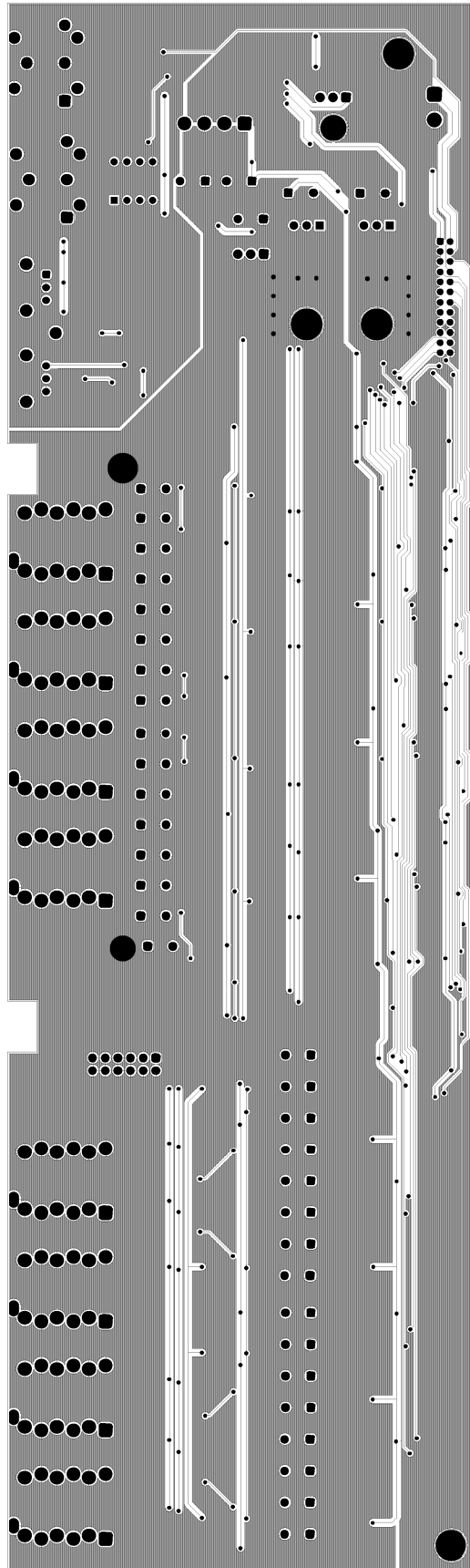

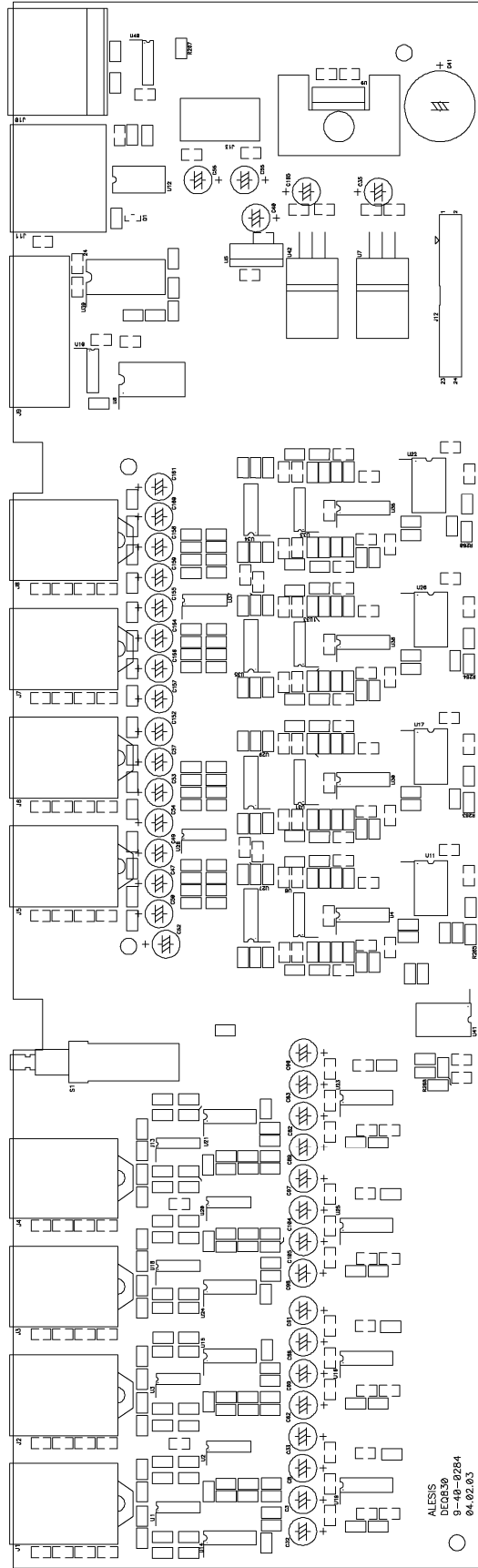

ALEIS
 DC0839
 94-02284
 94-02-00



MICROCONTROLLER

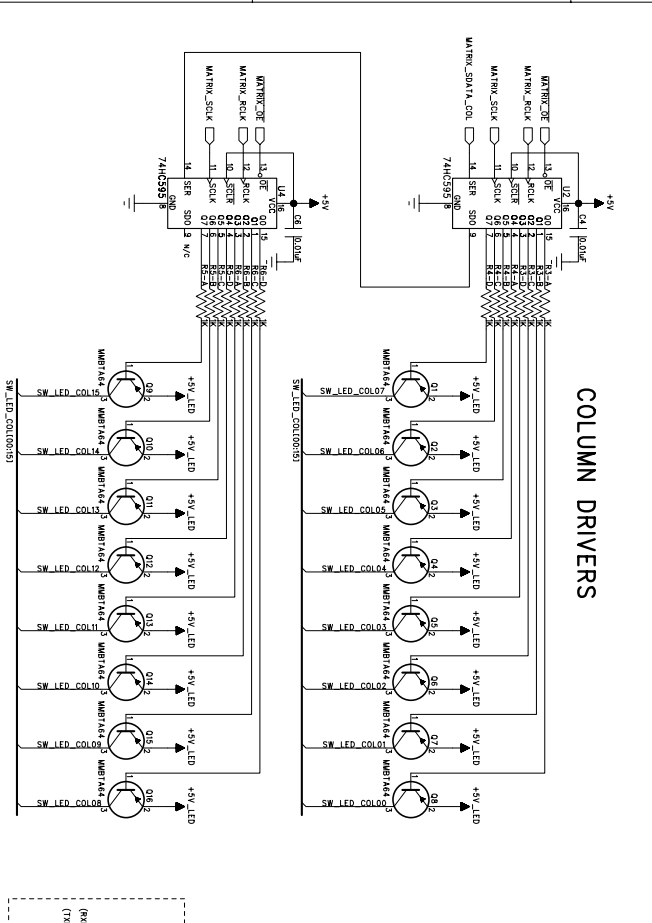
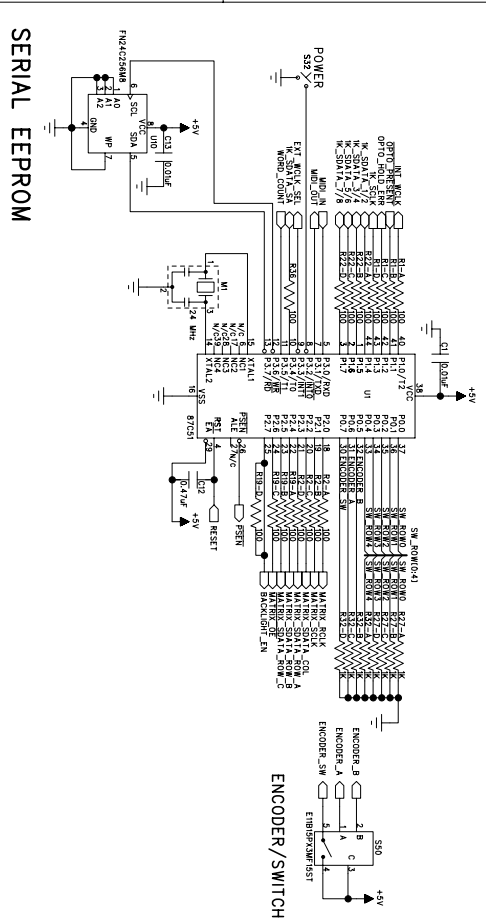

MASTER SECTION (RIGHT)

NOTE: FRONT SIDE COMPONENTS

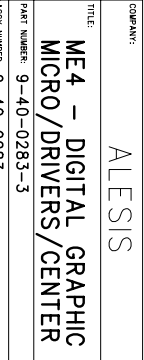
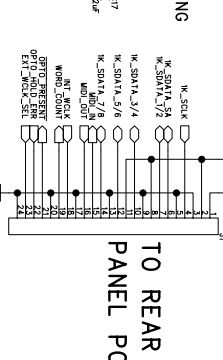
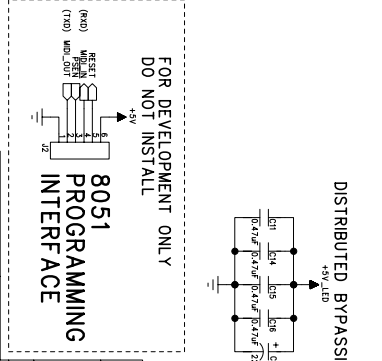
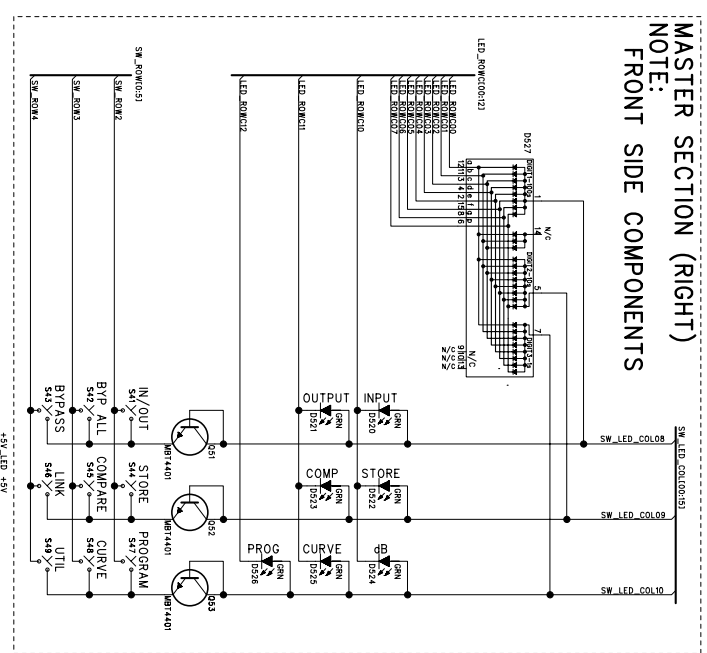

COMPANY: ALESIS	
TITLE: ME4 - DIGITAL GRAPHIC EQ MICRO/DRIVERS/CENTER	
PART NUMBER: 9-40-0283-3	REV: C
ASSY NUMBER: 9-40-0283	SIZE: C
FILENAME: ME4FP300A.SCH	SHEET: 1 OF 5
DATE: 12/13/02	RELEASED:
DESIGNED: MEYER/MARESH	

REV	DATE	APPROVED	ECO NO.	REVISION RECORD
1				

ROW DRIVERS

6

5

4

3

2

1

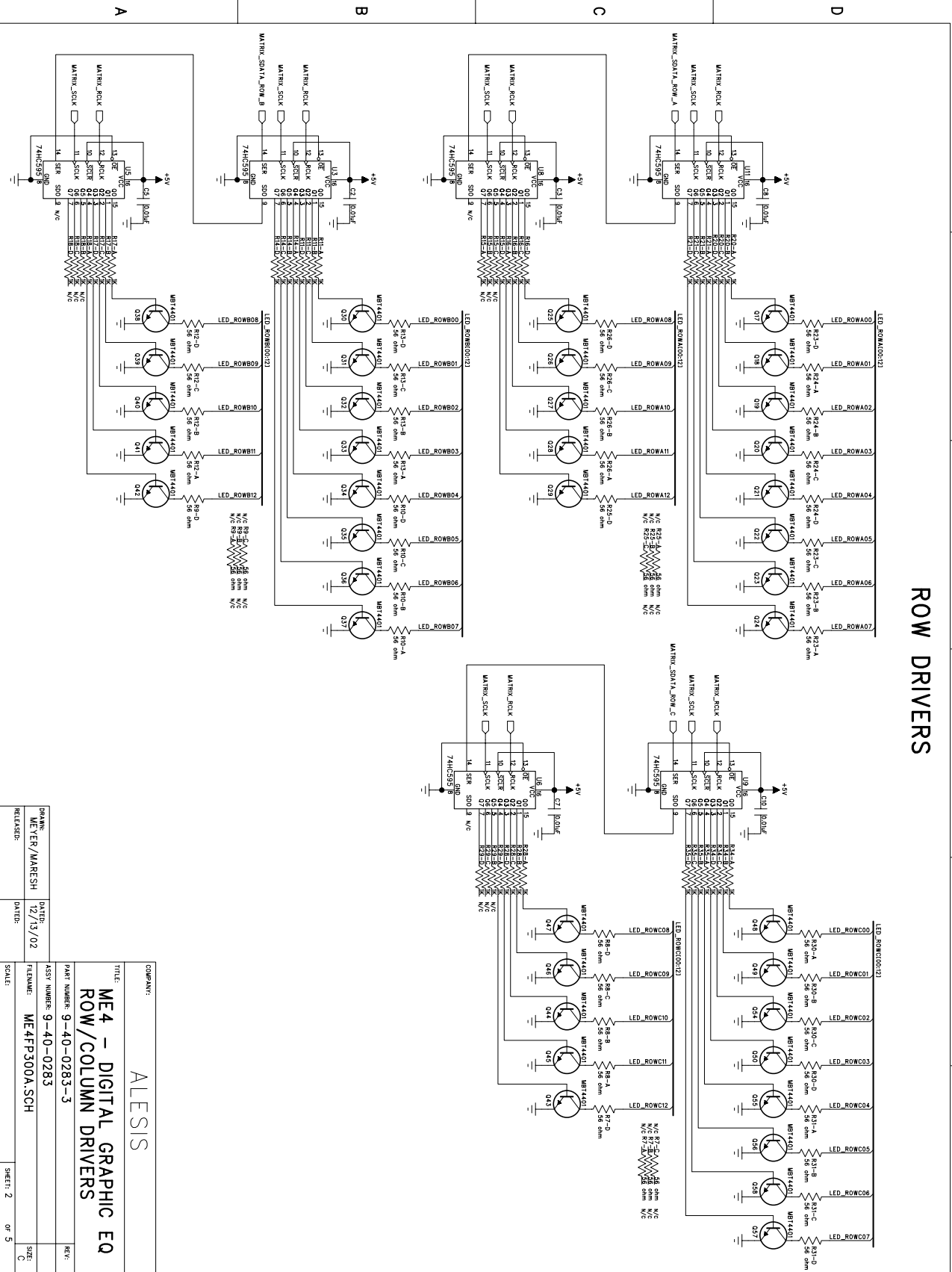

COMPANY:		ALEXIS	
TITLE:		ME4 - DIGITAL GRAPHIC EQ ROW/COLUMN DRIVERS	
DRAWN:	METTER/MARESH	DATE:	12/13/02
RELEASED:		ASSY NUMBER:	9-40-0283-3
FILENAME:		ME4FP300A.SCH	
SCALE:		SHEET: 2 OF 5	

REVISION RECORD		
LRN	ECO NO.	APPROVED DATE

6 5 4 3 2

CHANNEL

1 2 3 4 5 6 7 8

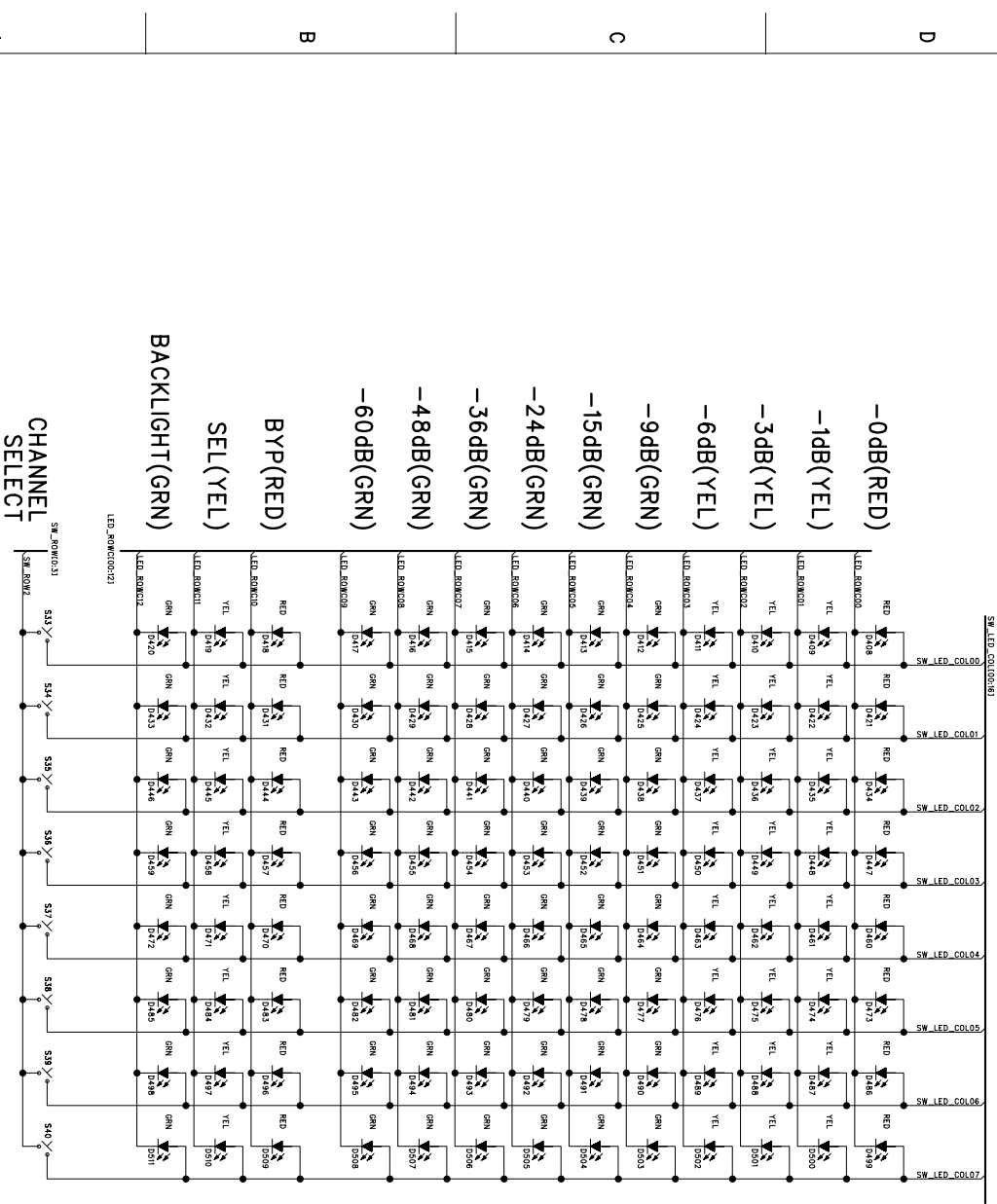

NOTE: THIS PAGE CONTAINS ONLY FRONT SIDE COMPONENTS

BRN: MEYER/MARESH	DATE: 12/15/02
RELEASED:	DATE:

COMPANY: ALEISIS	
TITLE: ME4 - DIGITAL GRAPHIC EQ METER/BYPASS/SELECT	
PART NUMBER: 9-40-0283-3	REV:
ASSY NUMBER: 9-40-0283	
FRIDAUER: ME4FP300A.SCH	SCALE: 1 OF 5

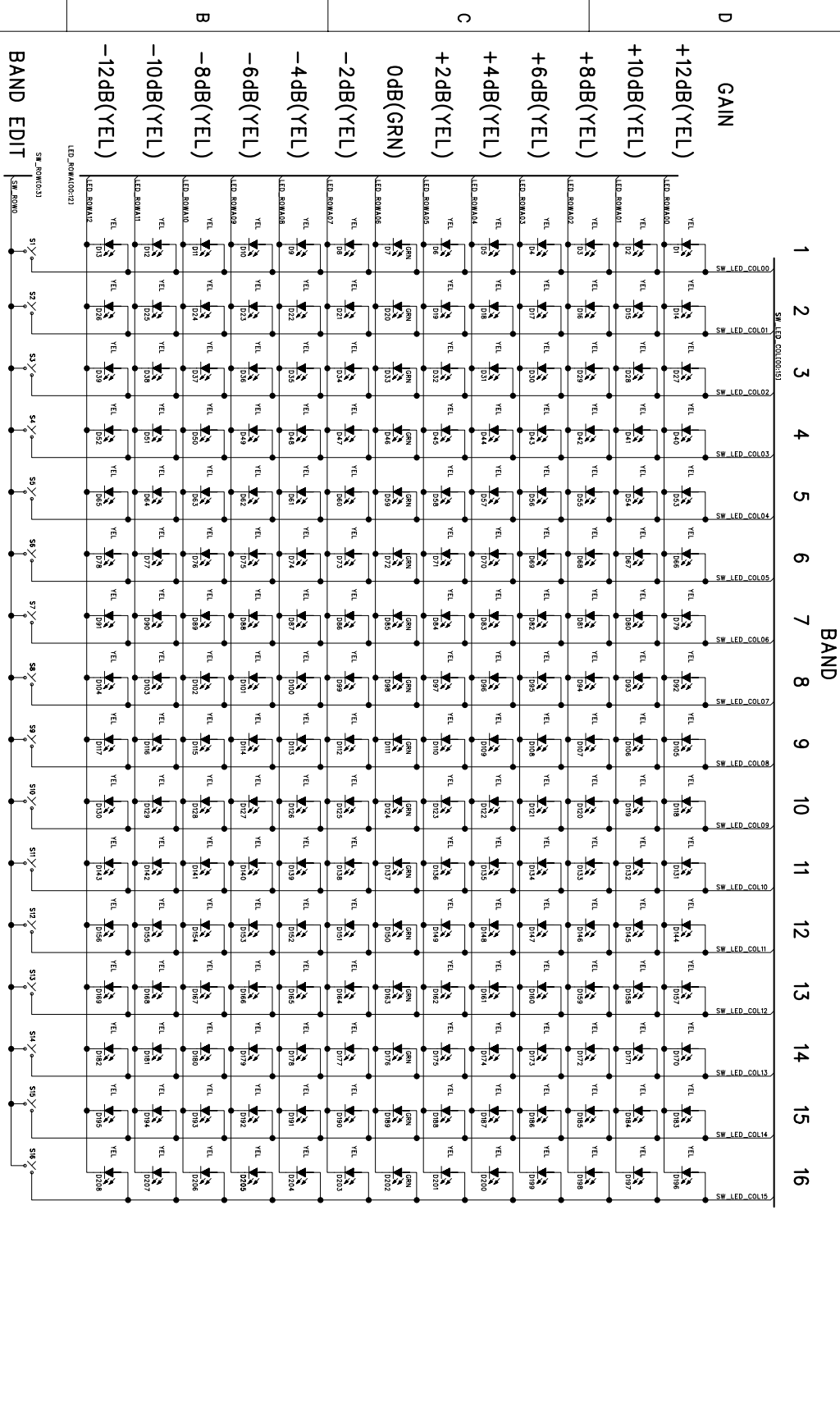

COMPANY: ALESIS

TITLE: ME4 - DIGITAL GRAPHIC EQ BANDS 1-16

PART NUMBER: 9-40-0283-3

ASSY NUMBER: 9-40-0283

FILENAME: ME4FP300A.SCH

DATE: 12/13/02

SCALE: SHEET: 4 OF 5

DRAWN: MEYER, MAREESH

RELEASED:

DATE:

REV: C

NOTE: THIS PAGE CONTAINS ONLY FRONT SIDE COMPONENTS

6 5 4 3 2 1

17 18 19 20 21 22 23 24 25 26 27 28 29 30

BAND

OUTPUT GAIN

D GAIN

+12DB(YEL)

+10DB(YEL)

+8DB(YEL)

+6DB(YEL)

+4DB(YEL)

+2DB(YEL)

0DB(GRN)

-2DB(YEL)

-4DB(YEL)

-6DB(YEL)

-8DB(YEL)

-10DB(YEL)

-12DB(YEL)

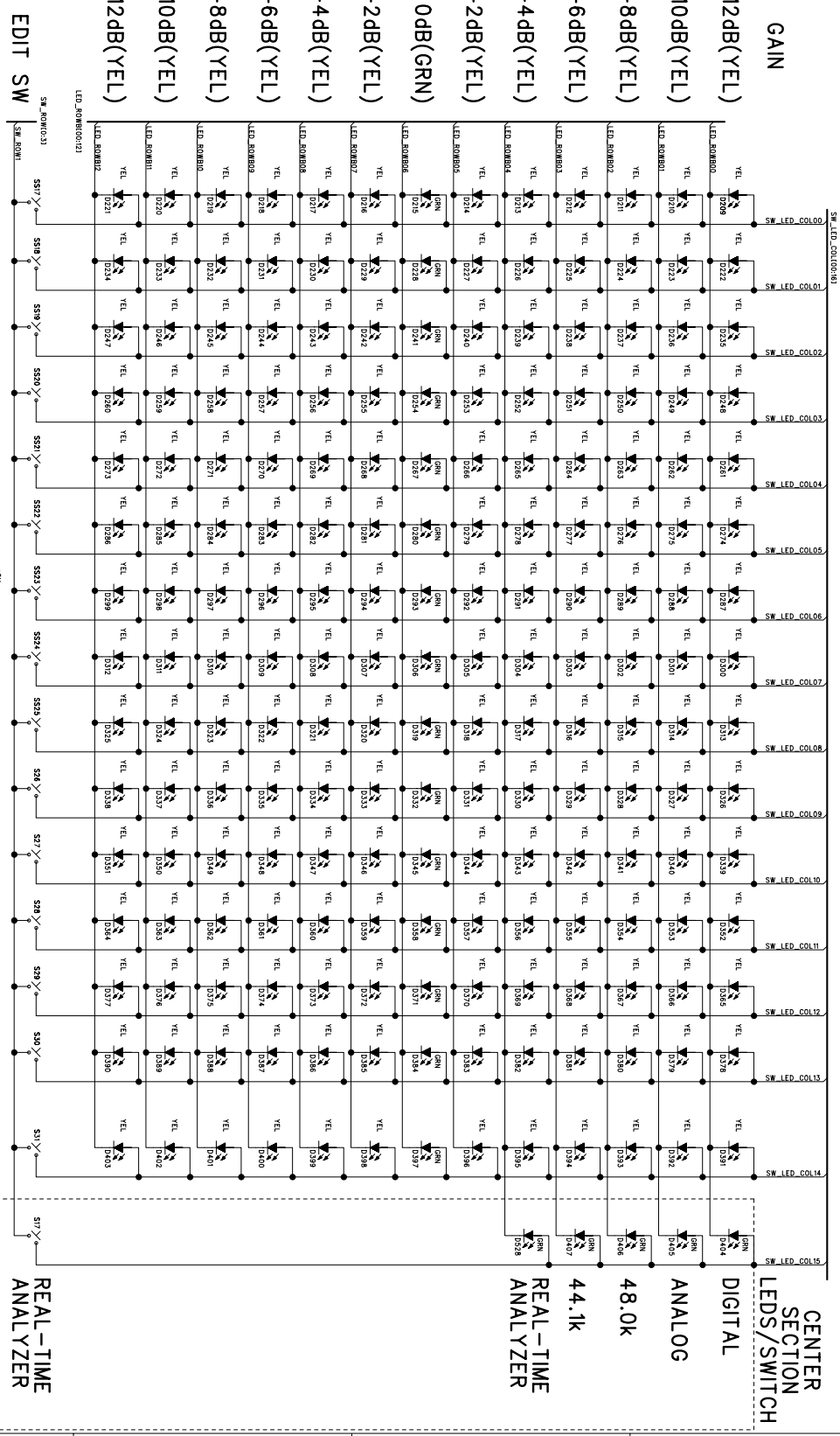

REAL-TIME ANALYZER

CENTER SECTION LEDS/SWITCH

DIGITAL

ANALOG

48.0K

44.1K

REAL-TIME ANALYZER

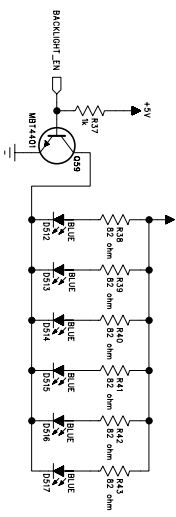

BACKLIGHT "ALEXIS" "DE0830"

COMPANY: ALESIS

TITLE: ME4 - DIGITAL GRAPHIC EQ BANDS 17-30 / LEVEL

PART NUMBER: 9-40-0283-3

ASSY NUMBER: 9-40-0283

DATE: 12/13/02

FILENAME: ME4FP300A.SCH

DESIGNER: MEYER/MARESH

DATE: 12/13/02

SCALE: SHEET: 5 OF 5

NOTE: THIS PAGE CONTAINS ONLY FRONT SIDE COMPONENTS

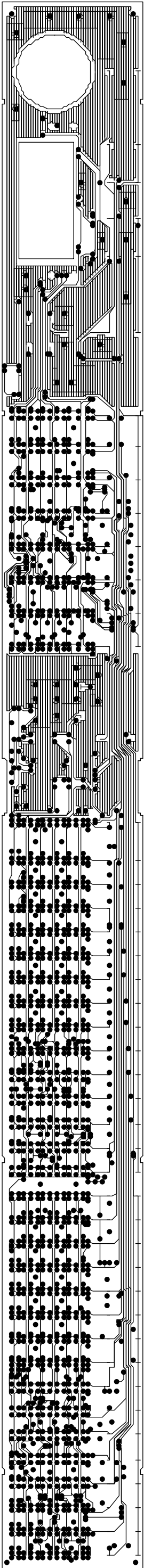

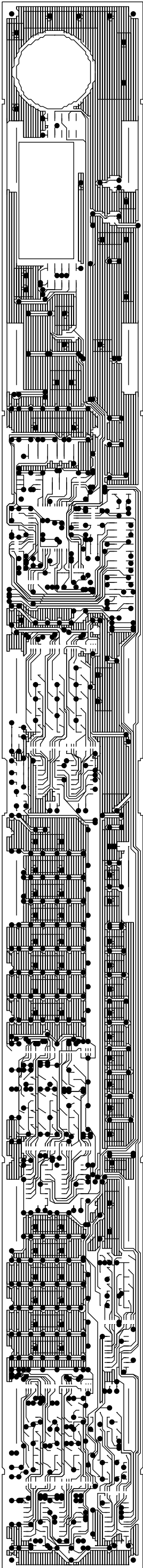

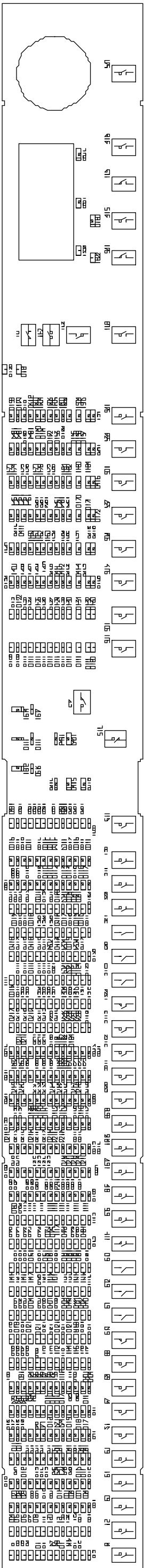

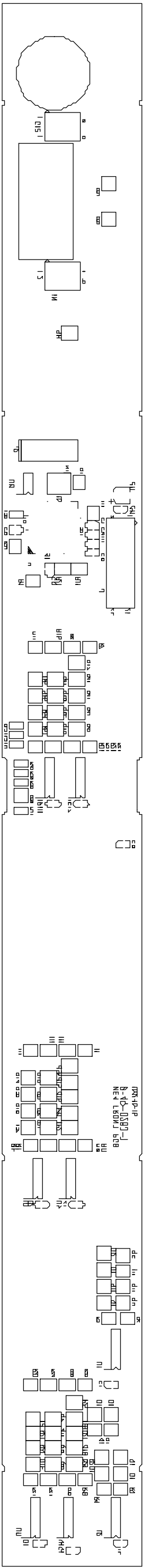

REVISION RECORD			
LTR	ECO NO.	APPROVED:	DATE:

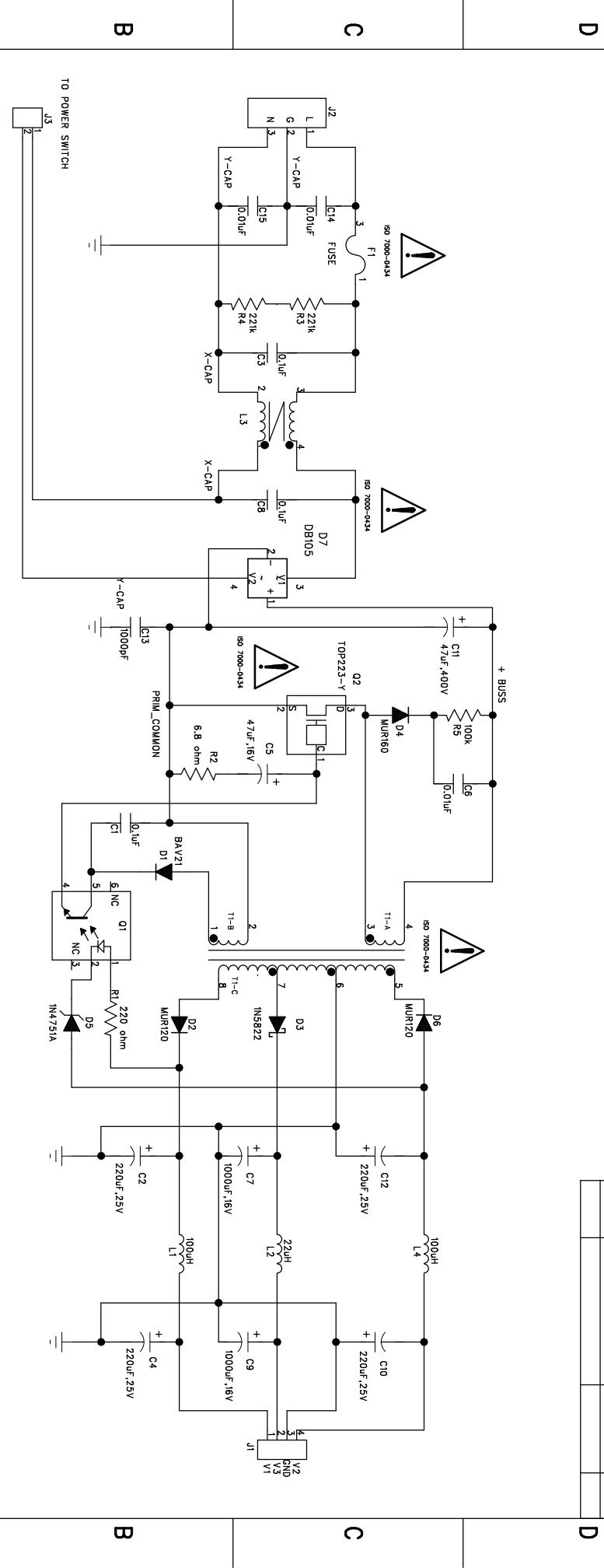

COMPANY: ALESIS STUDIO ELECTRONICS

TITLE: BB SWITCH-MODE POWER SUPPLY

PART NUMBER: 9-40-BB01-E

ASSY NUMBER: 9-79-BB01

FILENAME: BBMNE00a.SCH

SCALE: 1 OF 1

DATE: 1-23-2003

RELEASED: MBL

REV: E

SIZE: B

DRAWN:	MBL
DATE:	1-23-2003
RELEASED:	MBL
DATE:	1-23-2003

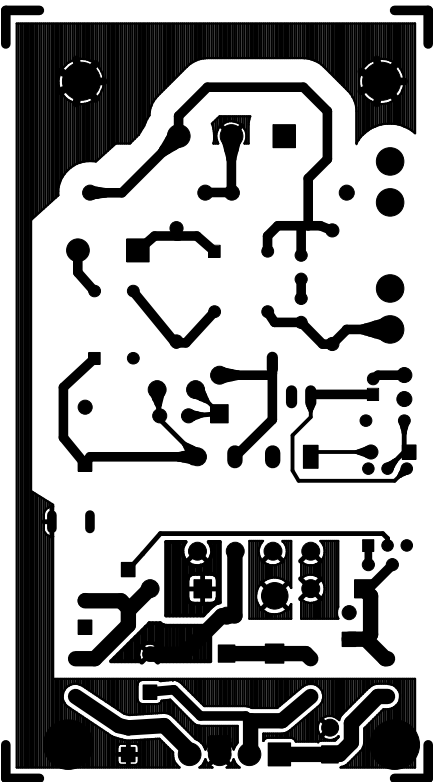

ALESIS 9-40-BB01-E "TOPTRACE"



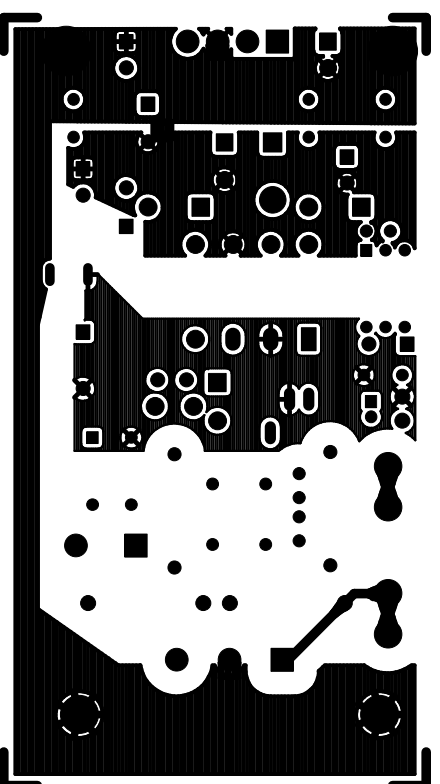

ALESIS 9-40-BB01-E "BOTTRACE"



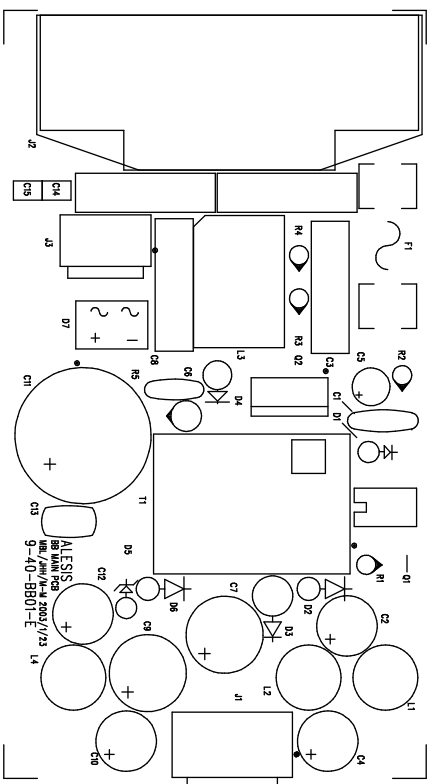

ALEXIS 9-40-BB01-E "TOPSILK"

